**STEP-DOWN, PWM CONTROL or PWM / PFM SWITCHABLE
SWITCHING REGULATOR CONTROLLER**

S-8520 / 8521 Series

The S-8520 / 8521 Series consists of CMOS step-down switching regulator-controllers with PWM control (S-8520 Series) and PWM / PFM switching control (S-8521 Series). These devices contain a reference voltage source, oscillation circuit, error amplifier, and other components.

The S-8520 Series provides low-ripple power, high-efficiency, and excellent transient characteristics thanks to a PWM control circuit capable of varying the duty ratio linearly from 0% up to 100%. The series also contains an error amplifier circuit as well as a soft-start circuit that prevents overshoot at startup.

The S-8521 Series works with either PWM control or PFM control, and can switch from one to the other. It normally operates using PWM control with a duty ratio of 25 to 100%, but under a light load, it automatically switches to PFM control with a duty ratio of 25%. This series ensures high efficiency over a wide range of conditions, from standby mode to operation of peripheral equipment.

With the addition of an external Pch power MOS FET or PNP transistor, a coil, capacitors, and a diode connected externally, these ICs can function as step-down switching regulators. They serve as ideal power supply units for portable devices when coupled with the SOT-23-5 small package, providing such outstanding features as low current consumption. Since this series can accommodate an input voltage of up to 16 V, it is also ideal when operating via an AC adapter.

■ Features

- Low current consumption

During operation:	60 μ A max. (A, B types)
	21 μ A max. (C, D types)
	100 μ A max. (E, F types)
During shutdown:	0.5 μ A max.
- Input voltage:

2.5 to 16 V (B, D, F types)
2.5 to 10 V (A, C, E types)
- Output voltage: Selectable between 1.5 V and 6.0 V in 0.1 V step
- Duty ratio:

0 to 100% PWM control (S-8520 Series)
25 to 100% PWM / PFM switching control (S-8521 Series)
- The only peripheral components that can be used with this IC are a Pch power MOS FET or PNP transistor, a coil, a diode, and capacitors (If a PNP transistor is used, a base resistance and a capacitor will also be required).
- Oscillation frequency:

180 kHz typ. (A, B types)
60 kHz typ. (C, D types)
300 kHz typ. (E, F types)
- Soft-start function:

8 ms. typ. (A, B types)
12 ms. typ. (C, D types)
4.5 ms. typ. (E, F types)
- With a shutdown function
- With a built-in overload protection circuit

Overload detection time:	4 ms. typ. (A type)
	14 ms. typ. (C type)
	2.6 ms. typ. (E type)
- Lead-free products

■ **Applications**

- On-board power supplies of battery devices for portable telephones, electronic notebooks, PDAs.
- Power supplies for audio equipment, including portable CD players and headphone stereo equipment.
- Fixed voltage power supply for cameras, video equipment and communications equipment.
- Power supplies for microcomputers.
- Conversion from four NiH or NiCd cells or two lithium-ion cells to 3.3 V / 3 V.
- Conversion of AC adapter input to 5 V / 3 V.

■ **Package**

Package Name	Drawing code		
	Package	Tape	Reel
SOT-23-5	MP005-A	MP005-A	MP005-A

■ Block Diagrams

1. S-8520 Series

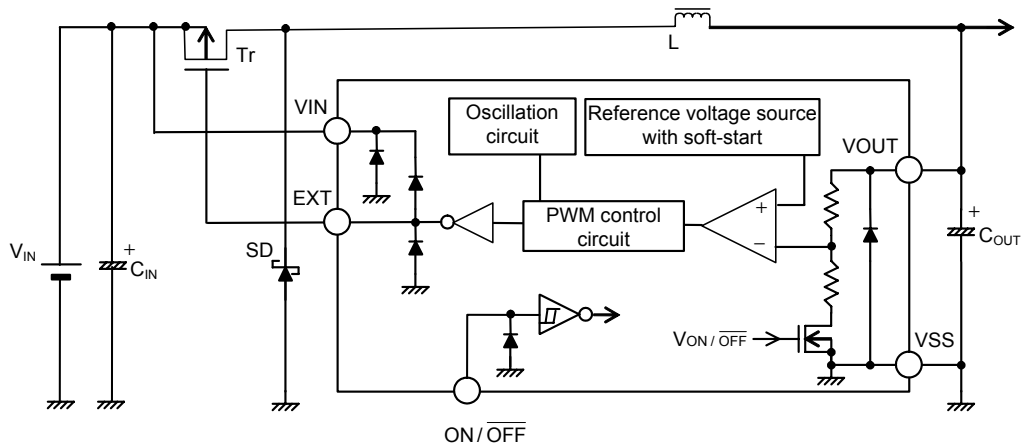

Remark All the diodes in the figure are parasitic diodes.

Figure 1

2. S-8521 Series

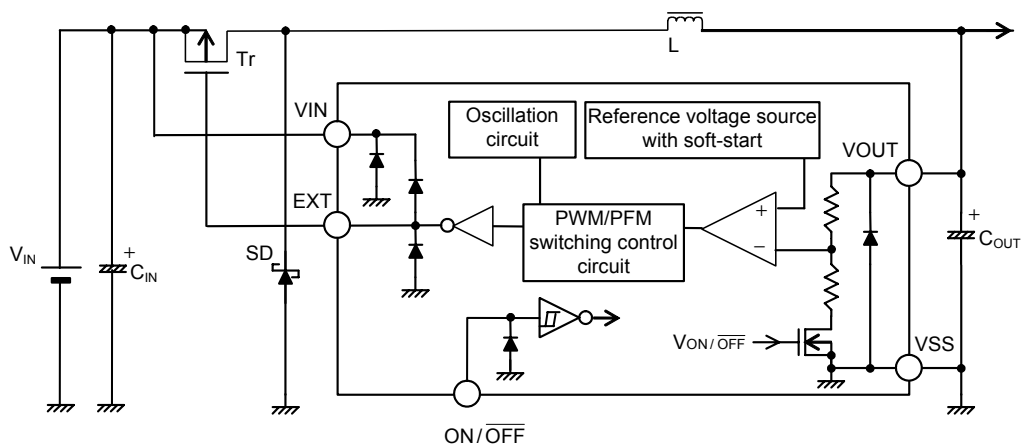

Remark All the diodes in the figure are parasitic diodes.

Figure 2

■ **Product Name Structure**

- The control types, product types, and output voltage for the S-8540 / 8541 series can be selected at the user's request. Please refer to the "1. **Product name**" for the definition of the product name and "2. **Product Name List**" for the full product names.

1. **Product name**

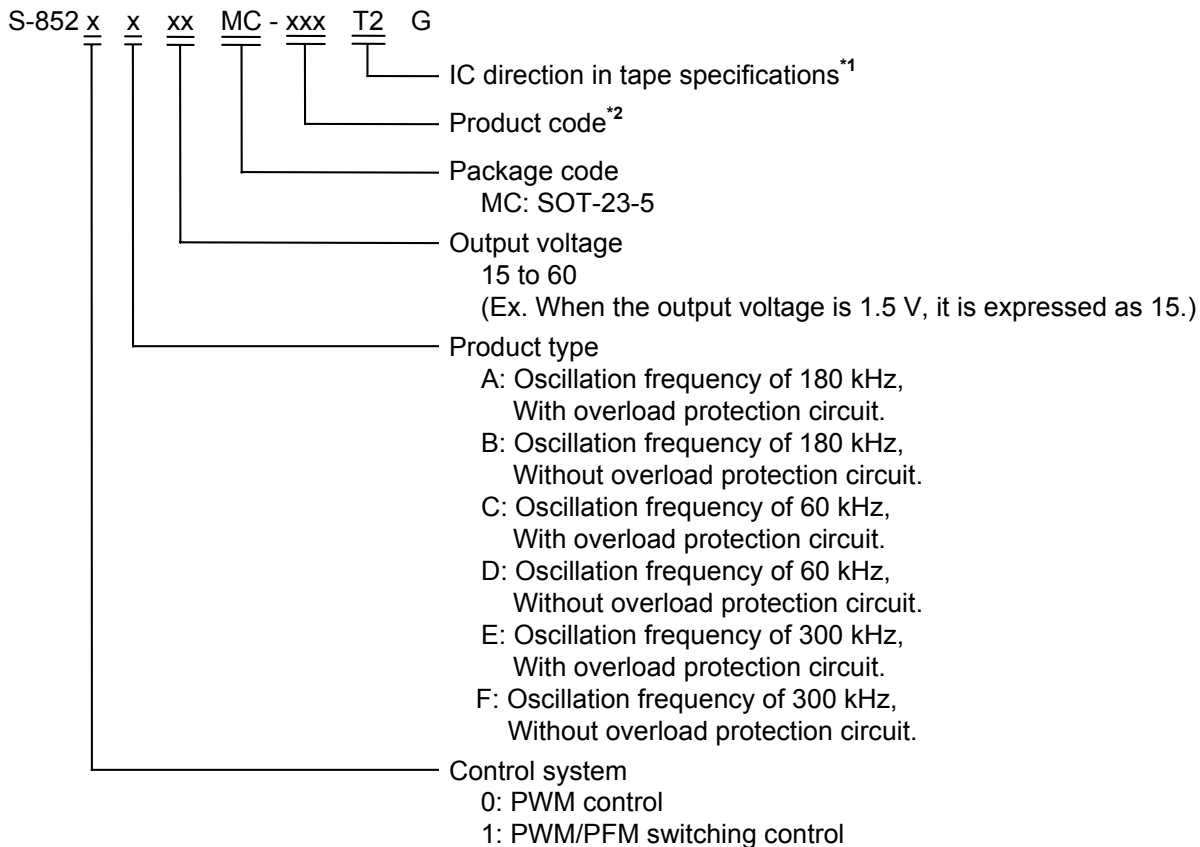

*1. Refer to the taping specifications at the end of this book.

*2. Refer to "2. **Product name list**".

2. Product name list

2.1 S-8520 Series

Table 1 (1 / 2)

Output voltage [V] \ Series	S-8520AxxMC Series	S-8520BxxMC Series	S-8520CxxMC Series
1.8	—	S-8520B18MC-ARDT2G	—
2.1	S-8520A21MC-AVGT2G	—	—
2.4	—	S-8520B24MC-ARJT2G	—
2.5	S-8520A25MC-AVKT2G	S-8520B25MC-ARKT2G	S-8520C25MC-BRKT2G
2.6	S-8520A26MC-AVLT2G	—	—
2.7	S-8520A27MC-AVMT2G	S-8520B27MC-ARMT2G	S-8520C27MC-BRMT2G
2.8	S-8520A28MC-AVNT2G	S-8520B28MC-ARNT2G	S-8520C28MC-BRNT2G
2.9	S-8520A29MC-AVOT2G	S-8520B29MC-AROT2G	S-8520C29MC-BROT2G
3.0	S-8520A30MC-AVPT2G	S-8520B30MC-ARPT2G	S-8520C30MC-BRPT2G
3.1	S-8520A31MC-AVQT2G	S-8520B31MC-ARQT2G	S-8520C31MC-BRQT2G
3.2	S-8520A32MC-AVRT2G	S-8520B32MC-ARRT2G	S-8520C32MC-BRRT2G
3.3	S-8520A33MC-AVST2G	S-8520B33MC-ARST2G	S-8520C33MC-BRST2G
3.4	S-8520A34MC-AVTT2G	S-8520B34MC-ARTT2G	S-8520C34MC-BRTT2G
3.5	S-8520A35MC-AVUT2G	S-8520B35MC-ARUT2G	S-8520C35MC-BRUT2G
3.6	S-8520A36MC-AVVT2G	S-8520B36MC-ARVT2G	S-8520C36MC-BRVT2G
4.0	—	S-8520B40MC-ARZT2G	—
4.3	—	S-8520B43MC-ASCT2G	—
5.0	S-8520A50MC-AWJT2G	S-8520B50MC-ASJT2G	S-8520C50MC-BSJT2G
5.3	—	S-8520B53MC-ASMT2G	—

Table 1 (2 / 2)

Output voltage [V] \ Series	S-8520DxxMC Series	S-8520ExxMC Series	S-8520FxxMC Series
1.5	—	—	S-8520F15MC-BNAT2G
1.6	—	S-8520E16MC-BJBT2G	—
1.8	—	S-8520E18MC-BJDT2G	S-8520F18MC-BNDT2G
2.0	—	—	S-8520F20MC-BNFT2G
2.5	S-8520D25MC-BVKT2G	S-8520E25MC-BJKT2G	S-8520F25MC-BNKT2G
2.6	—	—	S-8520F26MC-BNLT2G
2.7	S-8520D27MC-BVMT2G	—	S-8520F27MC-BNMT2G
2.8	S-8520D28MC-BVNT2G	—	S-8520F28MC-BNNT2G
2.9	S-8520D29MC-BVOT2G	—	—
3.0	S-8520D30MC-BVPT2G	S-8520E30MC-BJPT2G	S-8520F30MC-BNPT2G
3.1	S-8520D31MC-BVQT2G	—	S-8520F31MC-BNQT2G
3.2	S-8520D32MC-BVRT2G	—	—
3.3	S-8520D33MC-BVST2G	S-8520E33MC-BJST2G	S-8520F33MC-BNST2G
3.4	S-8520D34MC-BVTT2G	—	S-8520F34MC-BNTT2G
3.5	S-8520D35MC-BVUT2G	—	—
3.6	S-8520D36MC-BVVT2G	—	S-8520F36MC-BNVT2G
5.0	S-8520D50MC-BWJT2G	S-8520E50MC-BKJT2G	S-8520F50MC-BOJT2G
5.2	—	S-8520E52MC-BKLT2G	—
5.5	—	—	S-8520F55MC-BOOT2G

Remark Please contact the SII marketing department for the availability of product samples other than those specified above.

2-2. S-8521 Series

Table 2 (1 / 2)

Output voltage [V] \ Series	S-8521AxxMC Series	S-8521BxxMC Series	S-8521CxxMC Series
1.5	—	S-8521B15MC-ATAT2G	—
1.6	—	—	S-8521C16MC-BTBT2G
1.8	—	S-8521B18MC-ATDT2G	—
1.9	—	S-8521B19MC-ATET2G	—
2.0	—	S-8521B20MC-ATFT2G	—
2.1	—	S-8521B21MC-ATGT2G	—
2.3	—	S-8521B23MC-ATIT2G	—
2.5	S-8521A25MC-AXKT2G	S-8521B25MC-ATKT2G	S-8521C25MC-BTKT2G
2.6	—	S-8521B26MC-ATLT2G	—
2.7	S-8521A27MC-AXMT2G	S-8521B27MC-ATMT2G	S-8521C27MC-BTMT2G
2.8	S-8521A28MC-AXNT2G	S-8521B28MC-ATNT2G	S-8521C28MC-BTNT2G
2.9	S-8521A29MC-AXOT2G	S-8521B29MC-ATOT2G	S-8521C29MC-BTOT2G
3.0	S-8521A30MC-AXPT2G	S-8521B30MC-ATPT2G	S-8521C30MC-BTPT2G
3.1	S-8521A31MC-AXQT2G	S-8521B31MC-ATQT2G	S-8521C31MC-BTQT2G
3.2	S-8521A32MC-AXRT2G	S-8521B32MC-ATRT2G	S-8521C32MC-BTRT2G
3.3	S-8521A33MC-AXST2G	S-8521B33MC-ATST2G	S-8521C33MC-BTST2G
3.4	S-8521A34MC-AXTT2G	S-8521B34MC-ATTT2G	S-8521C34MC-BTTT2G
3.5	S-8521A35MC-AXUT2G	S-8521B35MC-ATUT2G	S-8521C35MC-BTUT2G
3.6	S-8521A36MC-AXVT2G	S-8521B36MC-ATVT2G	S-8521C36MC-BTVT2G
4.0	—	S-8521B40MC-ATZT2G	—
4.4	—	S-8521B44MC-AUDT2G	—
5.0	S-8521A50MC-AYJT2G	S-8521B50MC-AUJT2G	S-8521C50MC-BUJT2G

Table 2 (2 / 2)

Output voltage [V] \ Series	S-8521DxxMC Series	S-8521ExxMC Series	S-8521FxxMC Series
1.5	—	S-8521E15MC-BLAT2G	S-8521F15MC-BPAT2G
1.6	S-8521D16MC-BXBT2G	S-8521E16MC-BLBT2G	—
1.7	—	S-8521E17MC-BLCT2G	—
1.8	—	S-8521E18MC-BLDT2G	S-8521F18MC-BPDT2G
1.9	—	S-8521E19MC-BLET2G	S-8521F19MC-BPET2G
2.0	S-8521D20MC-BXFT2G	S-8521E20MC-BLFT2G	—
2.5	S-8521D25MC-BXKT2G	S-8521E25MC-BLKT2G	S-8521F25MC-BPKT2G
2.7	S-8521D27MC-BXMT2G	—	—
2.8	S-8521D28MC-BXNT2G	—	—
2.9	S-8521D29MC-BXOT2G	—	—
3.0	S-8521D30MC-BXPT2G	S-8521E30MC-BLPT2G	S-8521F30MC-BPPT2G
3.1	S-8521D31MC-BXQT2G	—	—
3.2	S-8521D32MC-BXRT2G	—	—
3.3	S-8521D33MC-BXST2G	S-8521E33MC-BLST2G	S-8521F33MC-BPST2G
3.4	S-8521D34MC-BXTT2G	—	S-8521F34MC-BPTT2G
3.5	S-8521D35MC-BXUT2G	S-8521E35MC-BLUT2G	—
3.6	S-8521D36MC-BXVT2G	—	S-8521F36MC-BPVT2G
4.0	S-8521D40MC-BXZT2G	—	S-8521F40MC-BPZT2G
5.0	S-8521D50MC-BYJT2G	S-8521E50MC-BMJT2G	S-8521F50MC-BQJT2G
5.5	—	—	S-8521F55MC-BQOT2G

Remark Please contact the SII marketing department for the availability of product samples other than those specified above.

■ Pin Configuration

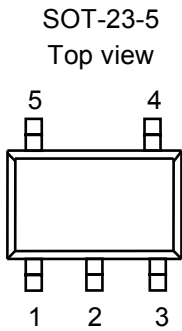

Figure 3

Table 3

Pin No.	Pin name	Pin description
1	ON/ $\overline{\text{OFF}}$	Shutdown pin “H”: Normal operation (Step-down operation) “L”: Step-down operation stopped (All circuits deactivated)
2	VSS	GND pin
3	VOOUT	Output voltage monitoring pin
4	EXT	Connection pin for external transistor
5	VIN	IC power supply pin

■ Absolute Maximum Ratings

Table 4

(Ta=25 °C unless otherwise specified)

Item	Symbol	Absolute maximum ratings	Unit	
VIN pin voltage	VIN	A, C, E types	VSS-0.3 to VSS+12	V
		B, D, F types	VSS-0.3 to VSS+18	
VOOUT pin voltage	VOOUT	A, C, E types	VSS-0.3 to VSS+12	
		B, D, F types	VSS-0.3 to VSS+18	
ON/ $\overline{\text{OFF}}$ pin voltage	VON/ $\overline{\text{OFF}}$	A, C, E types	VSS-0.3 to VSS+12	
		B, D, F types	VSS-0.3 to VSS+18	
EXT pin voltage	VEXT	VSS-0.3 to VIN+0.3		
EXT pin current	IEXT	±50	mA	
Power dissipation	PD	250	mW	
Operating ambient temperature	Topr	-40 to +85	°C	
Storage temperature	Tstg	-40 to +125		

Caution The absolute maximum ratings are rated values exceeding which the product could suffer physical damage. These values must therefore not be exceeded under any conditions.

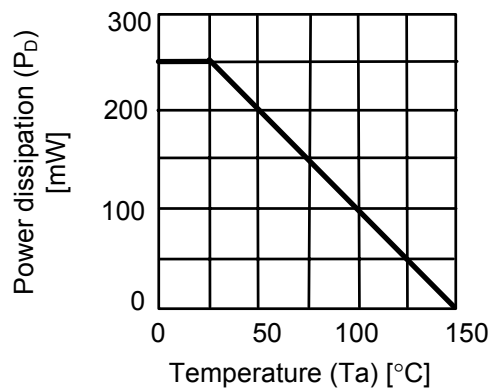

Figure 4 Power dissipation of Package (Before mounting)

■ Electrical Characteristics

1. A type, B type

Table 5

(Ta=25 °C unless otherwise specified)

Parameter	Symbol	Condition		Min.	Typ.	Max.	Unit	Measurement circuit
Output voltage ^{*1}	V _{OUT(E)}	—		V _{OUT(S)} × 0.976	V _{OUT(S)}	V _{OUT(S)} × 1.024	V	3
Input voltage	V _{IN}	—		2.5	—	10.0		2
Current consumption 1	I _{SS1}	V _{OUT} =V _{OUT(S)} ×1.2		—	35	60	μA	
Current consumption during shutdown	I _{SSS}	V _{ON} /OFF=0 V		—	—	0.5		
EXT pin output current	I _{EXTH}	V _{EXT} =V _{IN} -0.4 V	S-8520 / 8521x15 to 24	-2.3	-4.5	—	mA	—
			S-8520 / 8521x25 to 34	-3.7	-7.0	—		
			S-8520 / 8521x35 to 44	-5.3	-9.3	—		
			S-8520 / 8521x45 to 54	-6.7	-11.3	—		
			S-8520 / 8521x55 to 60	-8.0	-13.3	—		
	I _{EXTL}	V _{EXT} =0.4 V	S-8520 / 8521x15 to 24	+4.3	+8.4	—		
			S-8520 / 8521x25 to 34	+7.0	+13.2	—		
			S-8520 / 8521x35 to 44	+9.9	+17.5	—		
			S-8520 / 8521x45 to 54	+12.6	+21.4	—		
			S-8520 / 8521x55 to 60	+15.0	+25.1	—		
Line regulation	ΔV _{OUT1}	V _{OUT(S)} ≤2.0 V	V _{IN} =2.5 to 2.94 V	—	30	60	mV	3
		V _{OUT(S)} >2.0 V	V _{IN} =V _{OUT(S)} ×1.2 to 1.4	—	30	60		
Load regulation	ΔV _{OUT2}	Load current=10 μA to I _{OUT} ×1.25		—	30	60		
Output voltage temperature coefficient	$\frac{\Delta V_{OUT}}{\Delta T_a}$	Ta=-40 to +85 °C		—	±V _{OUT(S)} × 5E-5	—	V / °C	
Oscillation frequency	f _{osc}	Measured waveform at EXT pin.	V _{OUT(S)} ≤2.4 V	144	180	216	kHz	
			V _{OUT(S)} ≥2.5 V	153	180	207		
PWM / PFM control switching duty ratio (S-8521 Series)	PFMDuty	No load, Measured waveform at EXT pin.		15	25	40	%	
ON / OFF pin input voltage	V _{SH}	Judged oscillation at EXT pin		1.8	—	—	V	2
	V _{SL}	Judged oscillation stop at EXT pin		—	—	0.3		
ON / OFF pin input leakage current	I _{SH}	—		-0.1	—	0.1	μA	1
	I _{SL}	—		-0.1	—	0.1		
Soft start time	t _{ss}	—		4.0	8.0	16.0	ms	3
Overload detection time (A type)	t _{pro}	Duration from the time V _{OUT} is reduced to 0 V to the time the EXT pin obtains V _{IN} .		2.0	4.0	8.0		2
Efficiency	EFFI	—		—	93	—	%	3

External parts Coil: Sumida Corporation CD54 (47 μH)
 Diode: Matsushita Electric Industrial Co., Ltd. MA720 (Schottky type)
 Capacitor: Matsushita Electric Industrial Co., Ltd. TE (16 V, 22μF tantalum type)
 Transistor: Toshiba Corporation 2SA1213Y
 Base resistance (R_b): 0.68 kΩ
 Base capacitor (C_b): 2200 pF (Ceramic type)

The recommended components are connected to the IC, unless otherwise indicated.

V_{IN}=V_{OUT(S)}×1.2 V (V_{IN}=2.5 V if V_{OUT(S)}≤2.0 V), I_{OUT}=120 mA

The ON / OFF pin is connected to VIN pin.

*1. V_{OUT(S)}: Specified output voltage value, V_{OUT(E)}: Actual output voltage value

2. C type, D type

Table 6

(Ta=25 °C unless otherwise specified)

Parameter	Symbol	Condition		Min.	Typ.	Max.	Unit	Measurement circuit
Output voltage ^{*1}	V _{OUT(E)}	—		V _{OUT(S)} ×0.976	V _{OUT(S)}	V _{OUT(S)} ×1.024	V	3
Input voltage	V _{IN}	—		2.5	—	10.0	V	2
		C type	D type	2.5	—	16.0		
Current consumption 1	I _{SS1}	V _{OUT} =V _{OUT(S)} ×1.2		—	10	21	μA	2
Current consumption during shutdown	I _{SSS}	V _{ON} /OFF=0 V		—	—	0.5		
EXT pin output current	I _{EXTH}	V _{EXT} =V _{IN} -0.4 V	S-8520 / 8521x15 to 24	-2.3	-4.5	—	mA	—
			S-8520 / 8521x25 to 34	-3.7	-7.0	—		
			S-8520 / 8521x35 to 44	-5.3	-9.3	—		
			S-8520 / 8521x45 to 54	-6.7	-11.3	—		
			S-8520 / 8521x55 to 60	-8.0	-13.3	—		
	I _{EXTL}	V _{EXT} =0.4 V	S-8520 / 8521x15 to 24	+4.3	+8.4	—		
			S-8520 / 8521x25 to 34	+7.0	+13.2	—		
			S-8520 / 8521x35 to 44	+9.9	+17.5	—		
			S-8520 / 8521x45 to 54	+12.6	+21.4	—		
			S-8520 / 8521x55 to 60	+15.0	+25.1	—		
Line regulation	ΔV _{OUT1}	V _{OUT(S)} ≤2.0 V	V _{IN} =2.5 to 2.94 V	—	30	60	mV	3
		V _{OUT(S)} >2.0 V	V _{IN} =V _{OUT(S)} ×1.2 to 1.4	—	30	60		
Load regulation	ΔV _{OUT2}	Load current=10 μA to I _{OUT} ×1.25		—	30	60	mV	3
Output voltage temperature coefficient	$\frac{\Delta V_{OUT}}{\Delta T_a}$	Ta=-40 to +85 °C		—	±V _{OUT(S)} ×5E-5	—	V / °C	3
Oscillation frequency	f _{osc}	Measured waveform at EXT pin.	V _{OUT(S)} ≤2.4 V	45	60	75	kHz	3
			V _{OUT(S)} ≥2.5 V	48	60	72		
PWM / PFM control switching duty ratio (S-8521 Series)	PFMDuty	No load, Measured waveform at EXT pin		15	25	40	%	3
ON / OFF pin input voltage	V _{SH}	Judged oscillation at EXT pin		1.8	—	—	V	2
	V _{SL}	Judged oscillation stop at EXT pin		—	—	0.3		
ON / OFF pin input leakage current	I _{SH}	—		-0.1	—	0.1	μA	1
	I _{SL}	—		-0.1	—	0.1		
Soft start time	t _{ss}	—		6.0	12.0	24.0	ms	3
Overload detection time (C type)	t _{pro}	Duration from the time V _{OUT} is reduced to 0 V to the time the EXT pin obtains V _{IN} .		7.0	14.0	28.0		2
Efficiency	EFFI	—		—	93	—	%	3

External parts Coil: Sumida Corporation CD54 (47 μH)
 Diode: Matsushita Electric Industrial Co., Ltd. MA720 (Schottky type)
 Capacitor: Matsushita Electric Industrial Co., Ltd. TE (16 V, 22μF tantalum type)
 Transistor: Toshiba Corporation 2SA1213Y
 Base resistance (R_b): 0.68 kΩ
 Base capacitor (C_b): 2200 pF (Ceramic type)

The recommended components are connected to the IC, unless otherwise indicated.

V_{IN}=V_{OUT(S)}×1.2 V (V_{IN}=2.5 V if V_{OUT(S)}≤2.0 V), I_{OUT}=120 mA

The ON / OFF pin is connected to VIN pin.

*1. V_{OUT(S)}: Specified output voltage value, V_{OUT(E)}: Actual output voltage value

3. E type, F type

Table 7

(Ta=25 °C unless otherwise specified)

Parameter	Symbol	Condition	Min.	Typ.	Max.	Unit	Measurement circuit	
Output voltage*1	$V_{OUT(E)}$	—	$V_{OUT(S)} \times 0.976$	$V_{OUT(S)}$	$V_{OUT(S)} \times 1.024$	V	3	
Input voltage	V_{IN}	E type	2.5	—	10.0	V	2	
		F type	2.5	—	16.0			
Current consumption 1	I_{SS1}	$V_{OUT} = V_{OUT(S)} \times 1.2$	—	60	100	μA	2	
Current consumption during shutdown	I_{SSS}	$V_{ON / OFF} = 0 V$	—	—	0.5			
EXT pin output current	I_{EXTH}	$V_{EXT} = V_{IN} - 0.4 V$	S-8520 / 8521x15 to 24	-2.3	-4.5	—	mA	—
			S-8520 / 8521x25 to 34	-3.7	-7.0	—		
			S-8520 / 8521x35 to 44	-5.3	-9.3	—		
			S-8520 / 8521x45 to 54	-6.7	-11.3	—		
			S-8520 / 8521x55 to 60	-8.0	-13.3	—		
	I_{EXTL}	$V_{EXT} = 0.4 V$	S-8520 / 8521x15 to 24	+4.3	+8.4	—		
			S-8520 / 8521x25 to 34	+7.0	+13.2	—		
			S-8520 / 8521x35 to 44	+9.9	+17.5	—		
			S-8520 / 8521x45 to 54	+12.6	+21.4	—		
			S-8520 / 8521x55 to 60	+15.0	+25.1	—		
Line regulation	ΔV_{OUT1}	$V_{OUT(S)} \leq 2.0 V$	$V_{IN} = 2.5$ to 2.94 V	—	30	60	mV	3
		$V_{OUT(S)} > 2.0 V$	$V_{IN} = V_{OUT(S)} \times 1.2$ to 1.4	—	30	60		
Load regulation	ΔV_{OUT2}	Load current=10 μA to $I_{OUT} \times 1.25$	—	30	60			
Output voltage temperature coefficient	$\frac{\Delta V_{OUT}}{\Delta Ta}$	Ta=-40 to +85 °C	—	$\pm V_{OUT(S)} \times 5E-5$	—	V / °C		
Oscillation frequency	f_{osc}	Measured waveform at EXT pin.	$V_{OUT(S)} \leq 2.4 V$	225	300	375	kHz	
			$V_{OUT(S)} \geq 2.5 V$	240	300	360		
PWM / PFM control switching duty ratio (S-8521 Series)	PFMDuty	No load, Measured waveform at EXT pin	15	25	40	%		
ON / OFF pin input voltage	V_{SH}	Judged oscillation at EXT pin	1.8	—	—	V	2	
	V_{SL}	Judged oscillation stop at EXT pin	—	—	0.3			
ON / OFF pin input leakage current	I_{SH}	—	-0.1	—	0.1	μA	1	
	I_{SL}	—	-0.1	—	0.1			
Soft start time	t_{ss}	—	2.0	4.5	9.2		3	
Overload detection time (E type)	t_{pro}	Duration from the time V_{OUT} is reduced to 0 V to the time the EXT pin obtains V_{IN} .	1.3	2.6	4.5	ms	2	
Efficiency	EFFI	—	—	90	—	%	3	

External parts Coil: Sumida Corporation CD54 (47 μH)
 Diode: Matsushita Electric Industrial Co., Ltd. MA720 (Schottky type)
 Capacitor: Matsushita Electric Industrial Co., Ltd. TE (16 V, 22 μF tantalum type)
 Transistor: Toshiba Corporation 2SA1213Y
 Base resistance (R_b): 0.68 k Ω
 Base capacitor (C_b): 2200 pF (Ceramic type)

The recommended components are connected to the IC, unless otherwise indicated.

$V_{IN} = V_{OUT(S)} \times 1.2 V$ ($V_{IN} = 2.5 V$ if $V_{OUT(S)} \leq 2.0 V$), $I_{OUT} = 120 mA$

The ON / OFF pin is connected to VIN pin.

*1. $V_{OUT(S)}$: Specified output voltage value, $V_{OUT(E)}$: Actual output voltage value

■ Measurement Circuits

1.

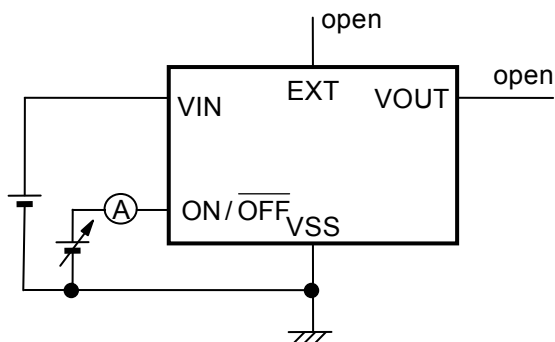

Figure 5

2.

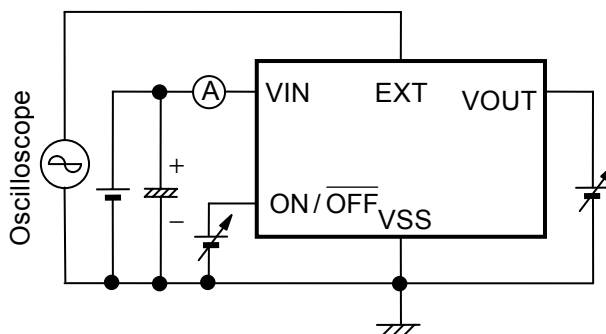

Figure 6

3.

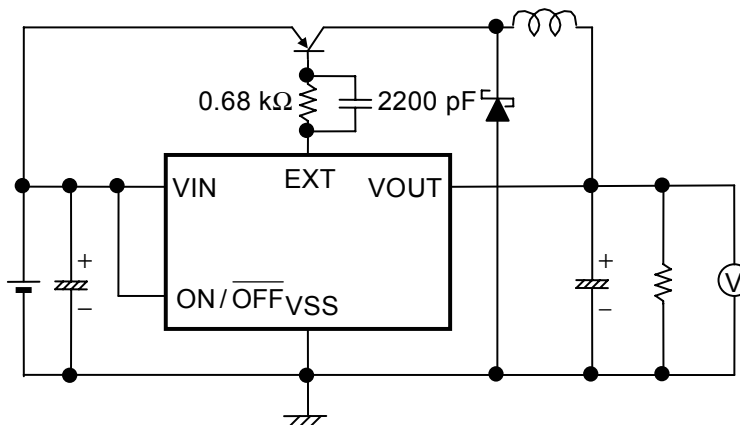

Figure 7

■ Operation

1. Switching control method

1.1 PWM control (S-8520 Series)

The S-8520 Series consists of DC-DC converters that employ a pulse-width modulation (PWM) system. This series is characterized by its low current consumption. In conventional PFM system DC-DC converters, pulses are skipped when they are operated with a low output load current, causing variations in the ripple frequency of the output voltage and an increase in the ripple voltage. Both of these effects constitute inherent drawbacks to those converters.

In the S-8520 series the pulse width varies in the range from 0 to 100% according to the load current, yet ripple voltage produced by the switching can easily be removed by a filter since the switching frequency is always constant. These converters thus provide a low-ripple voltage over wide range of input voltage and load current. And it will be skipped to be low current consumption when the pulse width is 0% or it is no load, input current voltage is high.

1.2 PWM / PFM switching control (S-8521 Series)

The S-8521 series is a DC-DC converter that automatically switches between a pulse width modulation method (PWM) and a pulse frequency modulation method (PFM), depending on the load current, and features low current consumption.

The S-8521 series operates under PWM control with the pulse width duty changing from 25 to 100% when the output load current is high. On the other hand, when the output current is low, the S-8541 series operates under PFM control with the pulse width duty fixed at 25%, and pulses are skipped according to the load current. The oscillator thus oscillates intermittently so that the resultant lower current consumption prevents a reduction in the efficiency when the load current is low. The switching point from PWM control to PFM control depends on the external devices (coil, diode, etc.), input voltage, and output voltage. This series is an especially efficient DC-DC converter at an output current of around 100 μ A.

2. Soft start function

The S-8520 / 8521 Series comes with a built-in soft start circuit. This circuit enables the output voltage (V_{OUT}) to rise gradually over the specified soft start time (t), when the power is switched on or when the ON/OFF pin remains at the "H" level. This prevents the output voltage from overshooting. However, the soft start function of this IC is not able to perfectly prevent a rush current from flowing to the load (Refer to **Figure 8**). Since this rush current depends on the input voltage and load conditions, we recommend that you evaluate it by testing performance with the actual equipment.

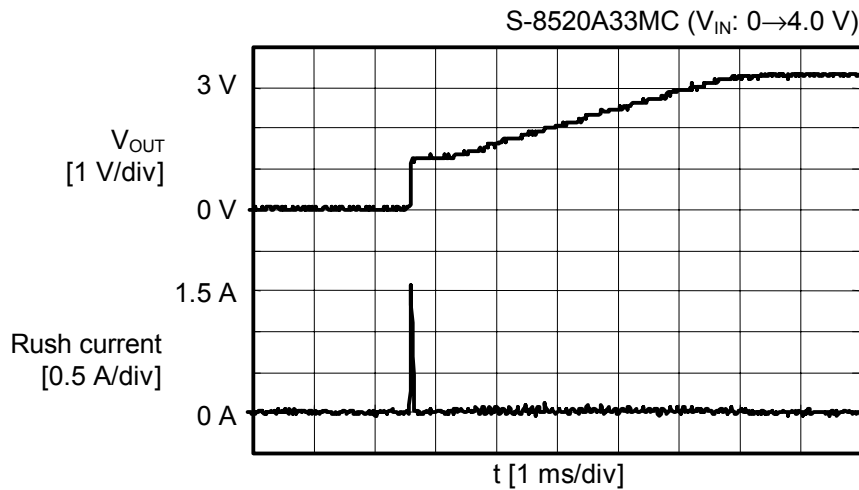

Figure 8 Waveforms of output voltage and rush current at soft start

3. ON/OFF pin (Shutdown pin)

This pin deactivates or activates the step-down operation. When the ON/OFF pin is set to "L", the V_{IN} voltage appears through the EXT pin, prodding the switching transistor to go off. All the internal circuits stop working, and substantial savings in current consumption are thus achieved. The ON/OFF pin is configured as shown in **Figure 9**. Since pull-up or pull-down is not performed internally, please avoid operating the pin in a floating state. Also, try to refrain from applying a voltage of 0.3 to 1.8 V to the pin, lest the current consumption increase. When this ON/OFF pin is not used, leave it coupled to the VIN pin.

Table 8

ON/OFF pin	CR Oscillation Circuit	Output Voltage
"H"	Activated	Set value
"L"	Deactivated	V_{SS}

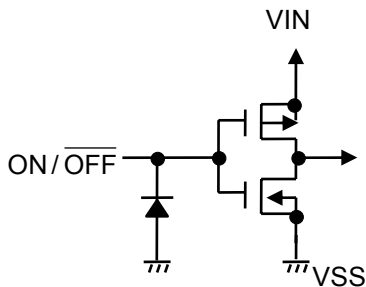

Figure 9

4. Overload protection circuit (A, C, E types)

The A, C and E types of the S-8520 / 8521 Series come with a built-in overload protection circuit.

If the output voltage falls because of an overload, the maximum duty state (100%) will continue. If this 100% duty state lasts longer than the prescribed overload detection time (t_{pro}), the overload protection circuit will hold the EXT pin at "H," thereby protecting the switching transistor and inductor. When the overload protection circuit is functioning, the reference voltage circuit will be activated by means of a soft start in the IC, and the reference voltage will rise slowly from 0 V. The reference voltage and the feedback voltage obtained by dividing the output voltage are compared to each other. So long as the reference voltage is lower, the EXT pin will be held at "H" to keep the oscillation inactive. If the reference voltage keeps rising and exceeds the feedback voltage, the oscillation will resume.

If the load is heavy when the oscillation is restarted, and the EXT pin holds the "L" level longer than the specified overload detection time (t_{pro}), the overload protection circuit will operate again, and the IC will enter intermittent operation mode, in which it repeats the actions described above. Once the overload state is eliminated, the IC resumes normal operation.

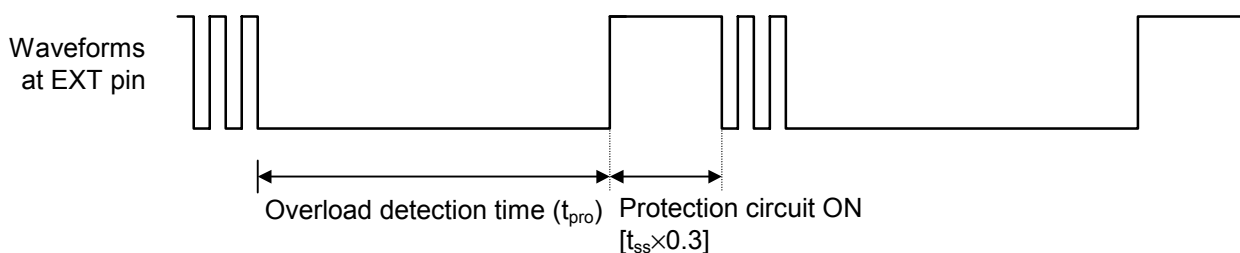

Figure 10 Waveforms appearing at EXT pin as the overload protection circuit operates

5. 100% duty cycle

The S-8520 / 8521 Series operates with a maximum duty cycle of 100%. When a B, D and F types products not provided with an overload protection circuit is used, the switching transistor can be kept ON to supply current to the load continually, even in cases where the input voltage falls below the preset output voltage value. The output voltage delivered under these circumstances is one that results from subtracting, from the input voltage, the voltage drop caused by the DC resistance of the inductance and the on-resistance of the switching transistor.

If an A, C and E types products provided with an overload protection circuit is used, this protection circuit will function when the 100% duty state has lasted longer than the preset overload detection time (t_{pro}), causing the IC to enter intermittent operation mode. Under these conditions, the IC will not be able to supply current to the load continually, unlike the case described in the preceding paragraph.

■ Selection of Series Products and Associated External Components

1. Method for selecting series products

The S-8520 / 8521 Series is classified into 12 types, according to the way the control systems (PWM control and PWM / PFM Switching control), the different oscillation frequencies, and the inclusion or exclusion of an overload protection circuit are combined one with another. Please select the type that best suits your needs by taking advantage of the features of each type described below.

1.1 Control systems

Two different control systems are available: PWM control system (S-8520 Series) and PWM / PFM switching control system (S-8521 Series).

If particular importance is attached to the operation efficiency while the load is on standby -- for example, in an application where the load current heavily varies from that in standby state as the load starts operating -- a high efficiency will be obtained in standby mode by selecting the PWM / PFM switching control system (S-8521 Series).

Moreover, for applications where switching noise poses a serious problem, the PWM control system (S-8520 Series), in which the switching frequency does not vary with the load current, is preferable because it can eliminate ripple voltages easily using a filter.

1.2 Oscillation frequencies

The oscillation frequencies are selectable in 180 kHz (A and B types), 60 kHz (C, D types), and 300 kHz (E, F types).

Because of their high oscillation frequency and low ripple voltage the A, B, E and F types offer excellent transient response characteristics. The products in these series allow the use of small-sized inductors since the peak current remains smaller in the same load current than with products of the other series. In addition, they can also be used with small output capacitors. These outstanding features make the A, B, E and F types ideal products for downsizing the associated equipment.

On the other hand, the C and D types, having a lower oscillation frequency, are characterized by a small self-consumption of current and excellent efficiency under light loads. In particular, the D type, which employs a PWM / PFM switching control system, enables the operation efficiency to be improved drastically when the output load current is approximately 100 μ A (Refer to "**Reference Data**").

1.3 Overload protection circuit

Products can be chosen either with an overload protection circuit (A, C, E types) or without one (B, D, F types).

Products with an overload protection circuit (A, C, E types) enter intermittent operation mode when the overload protection circuit operates to accommodate overloads or load short-circuiting. This protects the switching elements and inductors. Nonetheless, in an application where the load needs to be fed continually with a current by taking advantage of the 100 % duty cycle state, even if the input voltage falls below the output voltage value, a B, D, F types product will have to be used. Choose whichever product best handles the conditions of your application.

In making the selection, please keep in mind that the upper limit of the operating voltage range is either 10 V (A, C, E types) or 16 V (B, D, F types), depending on whether the product comes with an overload protection circuit built in.

Table 9 provides a rough guide for selecting a product type depending on the requirements of the application. Choose the product that gives you the largest number of circles (○).

Table 9

	S-8520 Series						S-8521 Series					
	A	B	C	D	E	F	A	B	C	D	E	F
An overload protection circuit is required	☆		☆		☆		☆		☆		☆	
The input voltage range exceeds 10 V		☆		☆		☆		☆		☆		☆
The efficiency under light loads (load current ≤ 1 mA) is an important factor							○	○	○	○		
To be operated with a medium load current (200 mA class)	○	○			○	○			○	○		
To be operated with a high load current (1 A class)	○	○			○	○	○	○			○	○
It is important to have a low-ripple voltage	○	○			⊙	⊙	○	○			⊙	⊙
Importance is attached to the downsizing of external components	○	○			⊙	⊙	○	○			⊙	⊙

Remark ☆ : Indispensable condition
 ○ : Superiority of requirement
 ⊙ : Particularly superiority of requirement

2. Inductor

The inductance value (L) greatly affects the maximum output current (I_{OUT}) and the efficiency (η).

The peak current (I_{PK}) increases by decreasing L and the stability of the circuit improves and I_{OUT} increases. If L is made even smaller, the efficiency falls causing a decline in the current drive capacity for the switching transistor, and I_{OUT} decreases.

The loss of I_{PK} by the switching transistor decreases by increasing L and the efficiency becomes maximum at a certain L value. Increasing L further decreases the efficiency due to the loss of coil DC resistance. I_{OUT} also decreases.

When the inductance is large in an S-8520 / 8521 series product, the output voltage may grow unstable in some cases, depending on the conditions of the input voltage, output voltage, and the load current. Perform sufficient evaluation under the actual condition and decide an optimum inductance.

The recommended inductances are 47 μ H for A, B, C, D types and 22 μ H for E, F types.

When choosing an inductor, attention to its allowable current should be paid since the current over the allowable value will cause magnetic saturation in the inductor, leading to a marked decline in efficiency.

An inductor should therefore be selected so as not I_{PK} to surpass its allowable current. The peak current (I_{PK}) is represented by the following equation in non-continuous operation mode:

$$I_{PK} = I_{OUT} + \frac{(V_{OUT} + V_F) \times (V_{IN} - V_{OUT})}{2 \times f_{osc} \times L \times (V_{IN} + V_F)}$$

Where f_{osc} is the oscillation frequency, and V_F the forward voltage of the diode.

3. Diode

The diode to be externally coupled to the IC should be a type that meets the following conditions:

- Its forward voltage is low (Schottky barrier diode recommended).
- Its switching speed is high (50 ns max.).
- Its reverse direction voltage is higher than V_{IN} .
- Its current rating is higher than I_{PK} .

4. Capacitors (C_{IN} , C_{OUT})

The capacitor inserted on the input side (C_{IN}) serves to lower the power impedance and to average the input current for better efficiency. Select the C_{IN} value according to the impedance of the power supplied. As a rough rule of thumb, you should use a value of 47 to 100 μ F, although the actual value will depend on the impedance of the power in use and the load current value.

For the output side capacitor (C_{OUT}), select one of large capacitance with low ESR (Equivalent Series Resistance) for smoothing the ripple voltage. However, notice that a capacitor with extremely low ESR (say, below 0.3 Ω), such as a ceramic capacitor, could make the output voltage unstable, depending on the input voltage and load current conditions. Instead, a tantalum electrolytic capacitor is recommended. A capacitance value from 47 to 100 μ F can serve as a rough yardstick for this selection.

5. External transistor

The external transistor of the enhancement (Pch) MOS FET type or bipolar (PNP) typ.

5.1 Enhancement (Pch) MOS FET type

The EXT pin is capable of directly driving a Pch MOS FET with a gate capacity of some 1000 pF. When a Pch MOS FET is chosen, because it has a higher switching speed than a PNP type bipolar transistor and because power losses due to the presence of a base current are avoided, efficiency will be 2 to 3 % higher than when other types of transistor are employed.

The important parameters to be kept in mind in selecting a MOS FET include the threshold voltage, breakdown voltage between gate and source, breakdown voltage between drain and source, total gate capacity, on-resistance, and the current rating.

The EXT pin swings from voltage V_{IN} over to voltage V_{SS} . If the input voltage is low, a MOS FET with a low threshold voltage has to be used so that the MOS FET will come on as required. If, conversely, the input voltage is high, select a MOS FET whose gate-source breakdown voltage is higher than the input voltage by at least several volts.

Immediately after the power is turned on, or when the power is turned off (that is, when the step-down operation is terminated), the input voltage will be imposed across the drain and the source of the MOS FET. Therefore, the transistor needs to have a drain-source breakdown voltage that is also several volts higher than the input voltage.

The total gate capacity and the on-resistance affect the efficiency.

The power loss for charging and discharging the gate capacity by switching operation will increase, when the total gate capacity becomes larger and the input voltage rises higher. Therefore the gate capacity affects the efficiency of power in a low load current region. If the efficiency under light loads is a matter of particular concern, select a MOS FET with a small total gate capacity.

In regions where the load current is high, the efficiency is affected by power losses caused due to the on-resistance of the MOS FET. Therefore, if the efficiency under heavy loads is particularly important for your application, choose a MOS FET with as low an on-resistance as possible.

As for the current rating, select a MOS FET whose maximum continuous drain current rating is higher than I_{PK} .

For reference purpose, some efficiency data has been included in this document. For applications with an input voltage range of 10 V or less, data was obtained by using TM6201 of Toyoda Industries Corporation. IRF7606, a standard of International Rectifier Corporation, was used for applications with an input voltage range over 10 V (Refer to "**Reference Data**").

5.2 Bipolar PNP type

Figure 11 shows a sample circuit diagram using Toshiba Corporation 2SA1213-Y for the bipolar transistor (PNP). The driving capacity for increasing the output current by means of a bipolar transistor is determined by the h_{FE} value and the R_b value of that bipolar transistor.

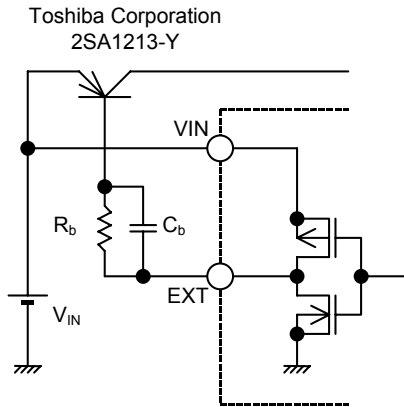

Figure 11

The R_b -value is given by the following equation:

$$R_b = \frac{V_{IN} - 0.7}{I_b} - \frac{0.4}{|I_{EXTL}|}$$

Find the necessary base current (I_b) using the (h_{FE}) value of bipolar transistor by the equation,

$$I_b = \frac{I_{PK}}{h_{FE}}, \text{ and select a smaller } R_b \text{ value.}$$

A small R_b value will certainly contribute to increasing the output current, but it will also adversely affect the efficiency. Moreover, in practice, a current may flow as the pulses or a voltage drop may take place due to the wiring resistance or some other reason. Determine an optimum value through experimentation.

In addition, if speed-up capacitor (C_b) is inserted in parallel with resistance R_b , as shown in Figure 11, the switching loss will be reduced, leading to a higher efficiency.

Select a C_b value by using the following equation as a guide:

$$C_b \leq \frac{1}{2\pi \times R_b \times f_{osc} \times 0.7}$$

Select a C_b value after performing sufficient evaluation since the optimum C_b value differs depending upon the characteristics of the bipolar transistor.

■ Standard Circuits

1. Using a bipolar transistor

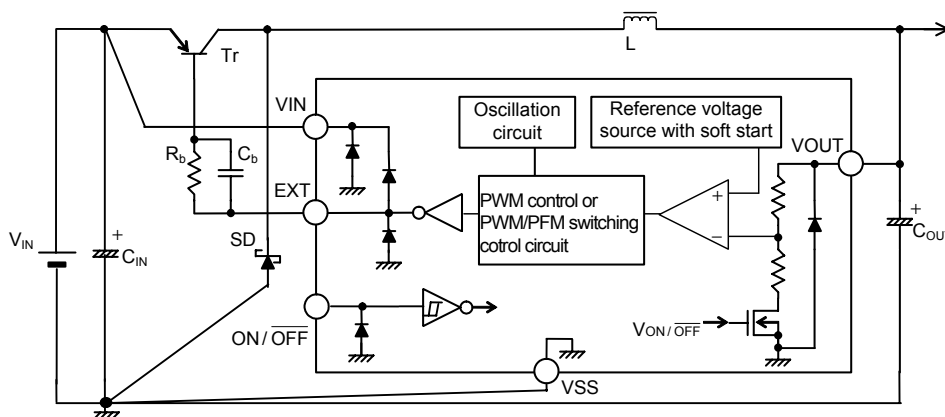

Figure 12

2. Using a Pch MOS FET transistor

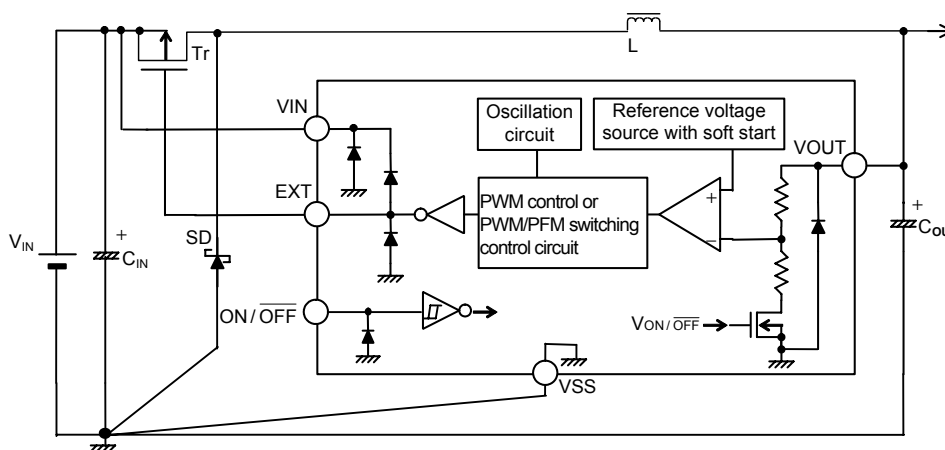

Figure 13

Caution The above connection diagram and constant will not guarantees successful operation. Perform through evaluation using the actual application to set the constant.

■ Precautions

- Mount the external capacitors, the diode and the coil as close as possible to the IC, and secure grounding at a single location.
- Characteristics ripple voltage and spike noise occur in IC containing switching regulators. Moreover, rush current flows at the time of a power supply injection. Because these largely depend on the coil, the capacitor and impedance of power supply used, fully check them using an actually mounted model.
- The overload protection circuit of this IC performs the protective function by detecting the maximum duty time (100 %). In choosing the components, make sure that over currents generated by short-circuits in the load, etc., will not surpass the allowable dissipation of the switching transistor and inductor.
- Make sure that dissipation of the switching transistor (especially at a high temperature) does not exceed the allowable dissipation of the package.
- Do not apply an electrostatic discharge to this IC that exceeds the performance ratings of the built-in electrostatic protection circuit.
- SII claims no responsibility for any and all disputes arising out of or in connection with any infringement of the products including this IC upon patents owned by a third party.

■ Application Circuits

1. External adjustment of output voltage

The S-8520 / 8521 Series allows you to adjust the output voltage or to set the output voltage to a value over the preset output voltage range (6 V) of the products of this series, when external resistances (R_A and R_B), and capacitor (C_C) are added, as illustrated in **Figure 14**. Moreover, a temperature gradient can be obtained by inserting a thermistor or other element in series with R_A and R_B .

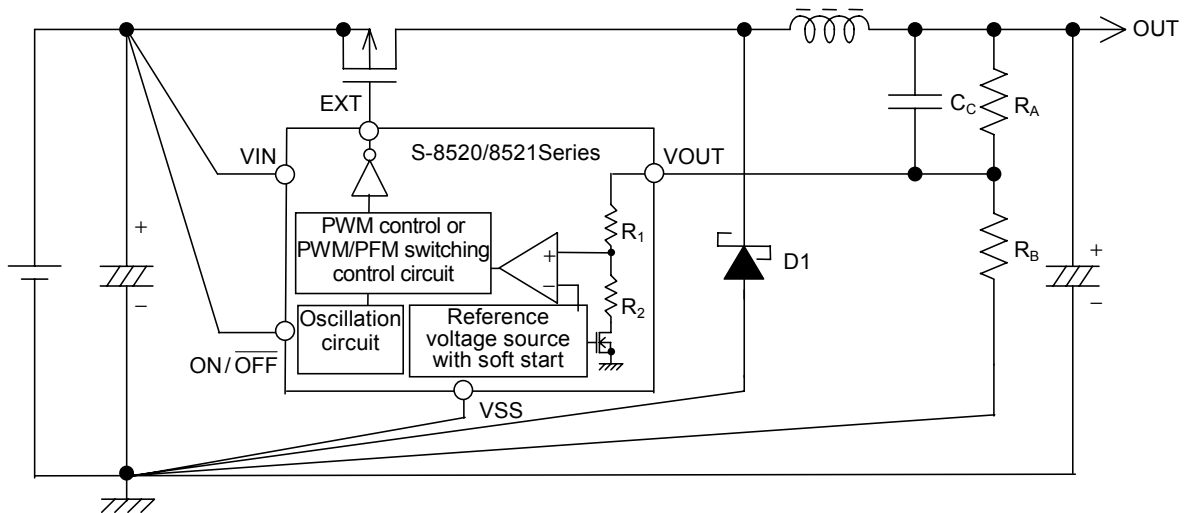

Figure 14

Caution The above connection diagram and constant will not guarantees successful operation. Perform through evaluation using the actual application to set the constant.

The S-8520 / 8521 Series have an internal impedance of R_1 and R_2 between the VOUT pin and the VSS pin, as shown in **Figure 14**.

Therefore, OUT (the output voltage) is determined by the output voltage value (V_{OUT}) of the S-8520 / 8521 Series, and the ratio of the parallel resistance value of external resistance (R_B) and internal resistances (R_1+R_2) of the IC, to external resistance (R_A). The output voltage is expressed by the following equation:

$$OUT = V_{OUT} + V_{OUT} \times R_A \div (R_B \parallel (R_1 + R_2))$$

The voltage accuracy of the OUT set by resistances (R_A and R_B) is not only affected by the IC's output voltage accuracy ($V_{OUT} \pm 2.4\%$), but also by the absolute precision of external resistances (R_A and R_B) in use and the absolute value deviations of internal resistances (R_1 and R_2) in the IC.

Let us designate the maximum deviations of the absolute value of R_A and R_B by R_{Amax} and R_{Bmax} , respectively, the minimum deviations by R_{Amin} and R_{Bmin} , respectively, and the maximum and minimum deviations of the absolute value of R_1 and R_2 in the IC by $(R_1+R_2)_{max}$ and $(R_1+R_2)_{min}$, respectively. Then, the minimum deviation value OUTmin and the maximum deviation value OUTmax of the OUT are expressed by the following equations:

$$OUT_{min} = V_{OUT} \times 0.976 + V_{OUT} \times 0.976 \times R_{Amin} \div (R_{Bmax} \parallel (R_1+R_2)_{max})$$

$$OUT_{max} = V_{OUT} \times 1.024 + V_{OUT} \times 1.024 \times R_{Amax} \div (R_{Bmin} \parallel (R_1+R_2)_{min})$$

The voltage accuracy of the OUT cannot be made higher than the output voltage accuracy ($V_{OUT} \pm 2.4\%$) of the IC itself, without adjusting the R_A and R_B involved. The closer the voltage value of the output OUT and the output voltage value (V_{OUT}) of the IC are brought to one other, the more the output voltage remains immune to deviations in the absolute accuracy of R_A and R_B and the absolute value of R_1 and R_2 in the IC. In particular, to suppress the influence of deviations in R_1 and R_2 in the IC, a major contributor to deviations in the OUT, the R_A and R_B must be limited to a much smaller value than that of R_1 and R_2 in the IC.

On the other hand, a reactive current flows through R_A and R_B . This reactive current must be reduced to a negligible value with respect to the load current in the actual use of the IC so that the efficiency characteristics will not be degraded. This requires that the value of R_A and R_B be made sufficiently large.

However, too large a value (more than 1 M Ω) for the R_A and R_B would make the IC vulnerable to external noise. Check the influence of this value on actual equipment.

There is a tradeoff between the voltage accuracy of the OUT and the reactive current. This should be taken into consideration based on the requirements of the intended application.

Deviations in the absolute value of the internal resistances (R_1 and R_2) in the IC vary with the output voltage of the S-8520 / 8521 Series, and are broadly classified as follows:

Table 10

Output voltage	Deviations in the absolute value of R_1 and R_2 in the IC
1.5 V to 2.0 V	5.16 M Ω to 28.9 M Ω
2.1 V to 2.5 V	4.44 M Ω to 27.0 M Ω
2.6 V to 3.3 V	3.60 M Ω to 23.3 M Ω
3.4 V to 4.9 V	2.44 M Ω to 19.5 M Ω
5.0 V to 6.0 V	2.45 M Ω to 15.6 M Ω

When a value of R_1+R_2 given by the equation indicated below is taken in calculating the voltage value of the output OUT, a median voltage deviation will be obtained for the OUT.

$$R_1+R_2=2\div(1\div\text{maximum deviation in absolute value of } R_1 \text{ and } R_2+1\div\text{minimum deviation in absolute value of } R_1 \text{ and } R_2)$$

Moreover, add a capacitor (C_C) in parallel to the external resistance (R_A) in order to avoid output oscillations and other types of instability. (Refer to **Figure 14**.)

Make sure that C_C is larger than the value given by the following equation:

$$C_C \text{ (F)} \geq 1\div(2\times\pi\times R_A \text{ (\Omega)}\times 7.5 \text{ kHz})$$

If a large C_C value is selected, a longer soft start time than the one set up in the IC will be set.

- SII is equipped with a tool that allows you to automatically calculate the necessary resistance values of R_A and R_B from the required voltage accuracy of the OUT. SII will be pleased to assist its customers in determining the R_A and R_B values. Should such assistance be desired, please inquire.
- Moreover, SII also has ample information on which peripheral components are suitable for use with this IC and data concerning the deviations in the IC's characteristics. We are ready to help our customers with the design of application circuits. Please contact the SII Components Sales Dept.

*1. // shows the combined resistance in parallel.

Caution The above connection diagram and constant will not guarantees successful operation. Perform through evaluation using the actual application to set the constant.

■ **Characteristics (Typical Data)**

1. **Examples of major parameters characteristics**

(1) **Current consumption (I_{SS1})-Input voltage (V_{IN})**

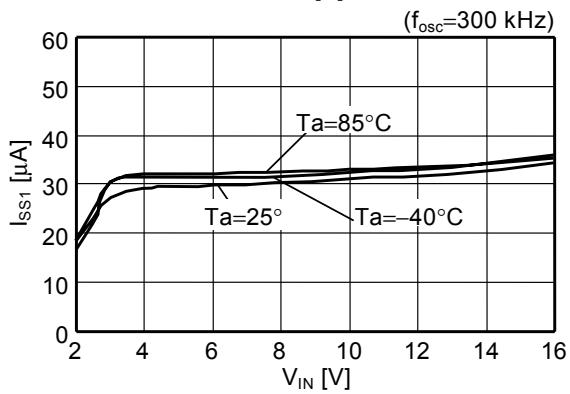
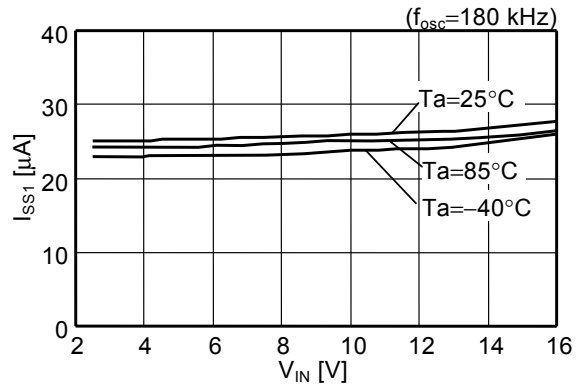
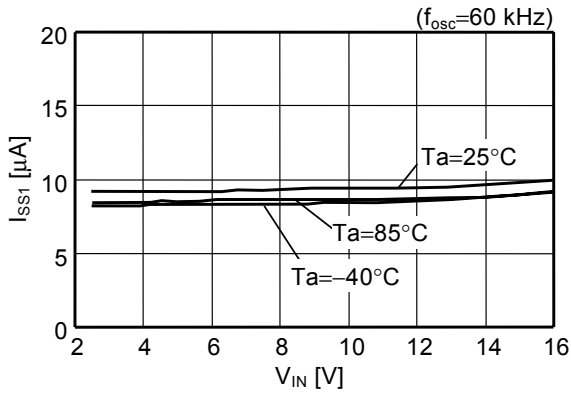

(2) **Oscillation frequency (f_{osc})-Input voltage (V_{IN})**

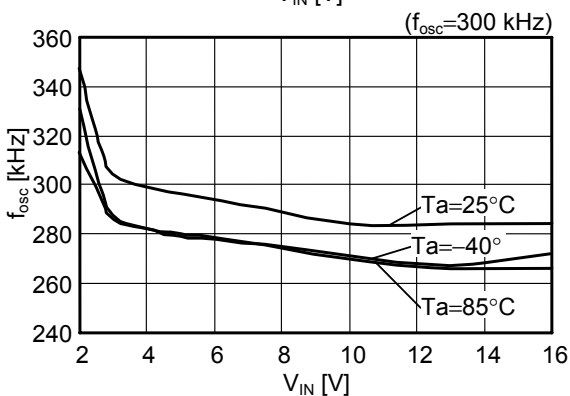
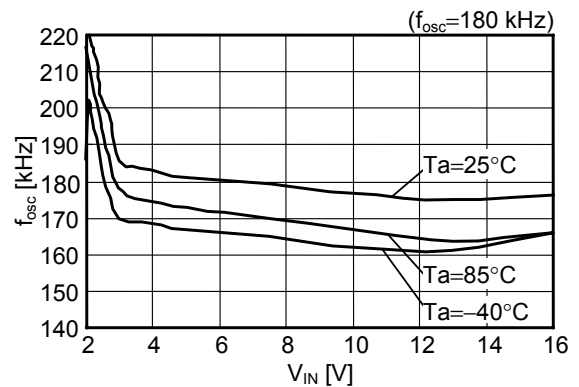
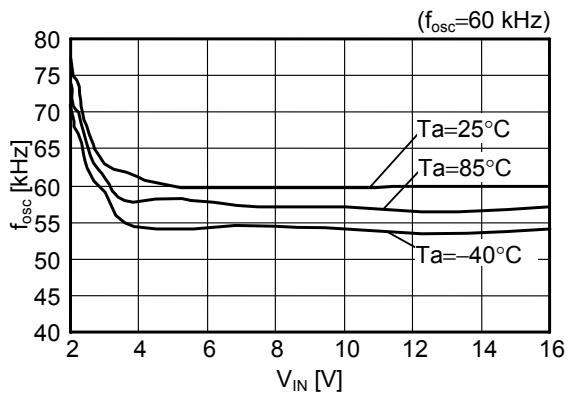

(3) EXT pin output current "H" (I_{EXTH})-Input voltage (V_{IN}) (4) EXT pin output current "L" (I_{EXTL})-Input voltage (V_{IN})

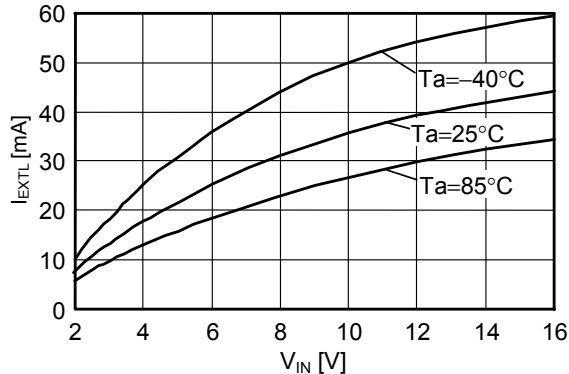
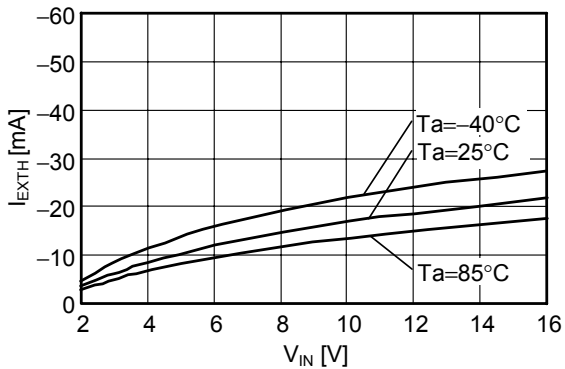

(5) Soft start time (t_{SS})-Input voltage (V_{IN})

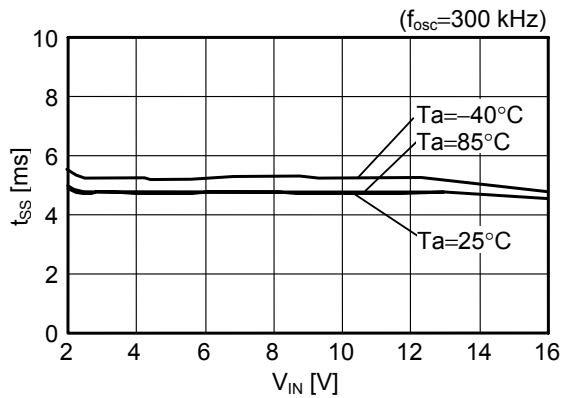
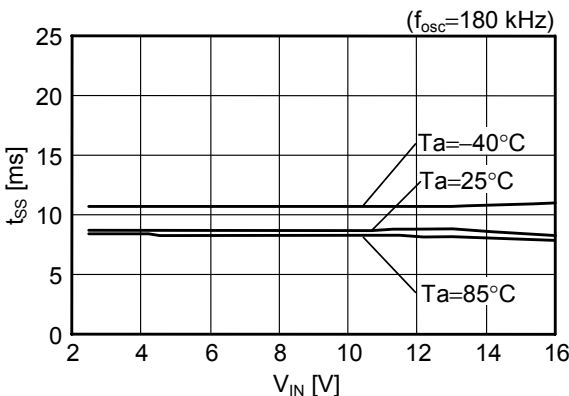
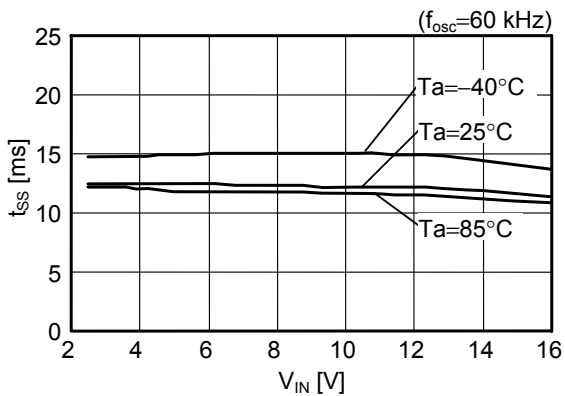

(6) Overload detection time (t_{pro})- Input voltage (V_{IN})

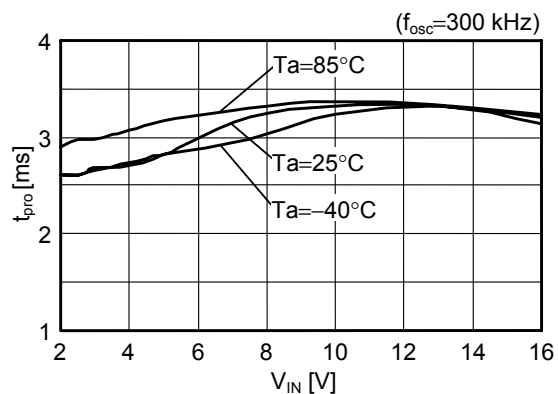
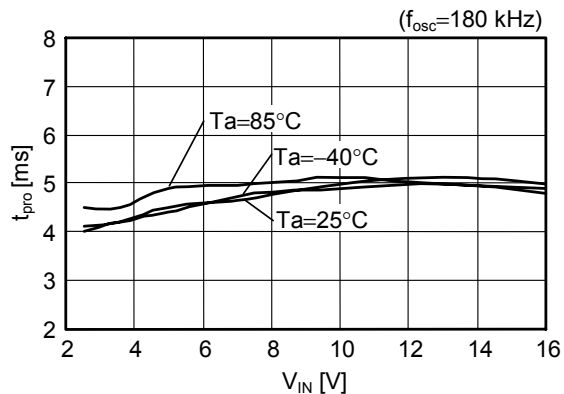
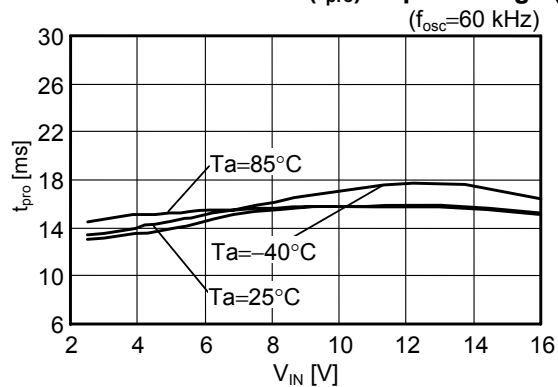

(7) ON/OFF pin input voltage "H" (V_{SH})-Input voltage (V_{IN}) **(8) ON/OFF pin input voltage "L" (V_{SL})-Input voltage (V_{IN})**

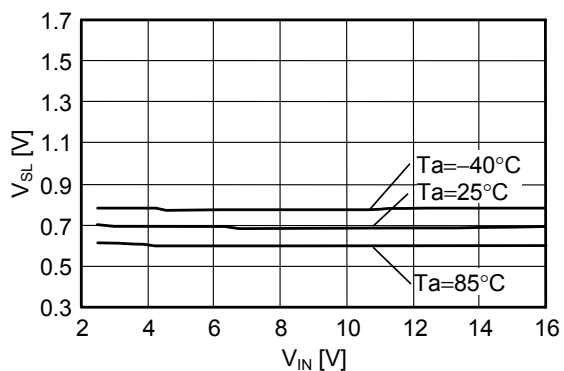
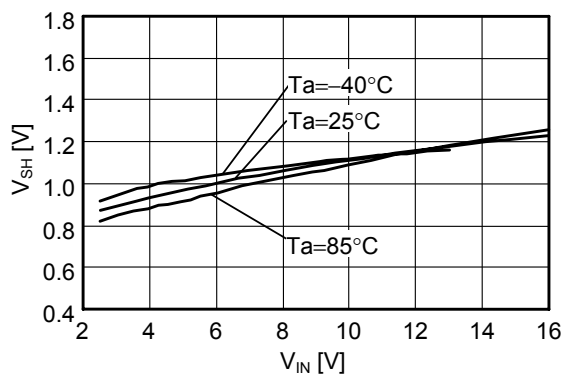

(9) Output voltage (V_{OUT})-Input voltage(V_{IN})

S-8521B30MC

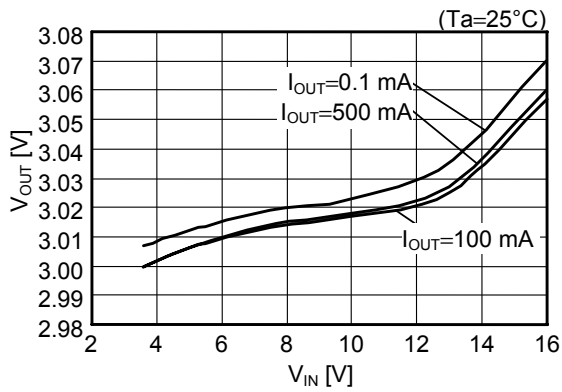

S-8521B50MC

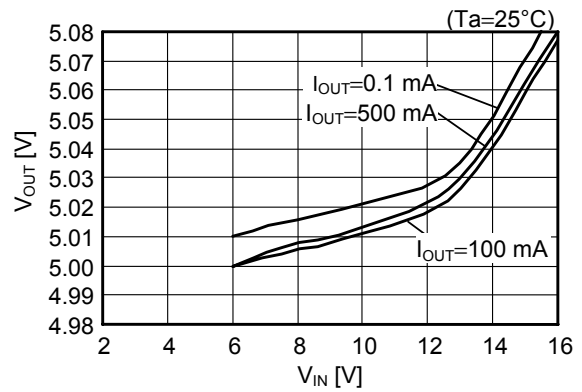

S-8521F33MC

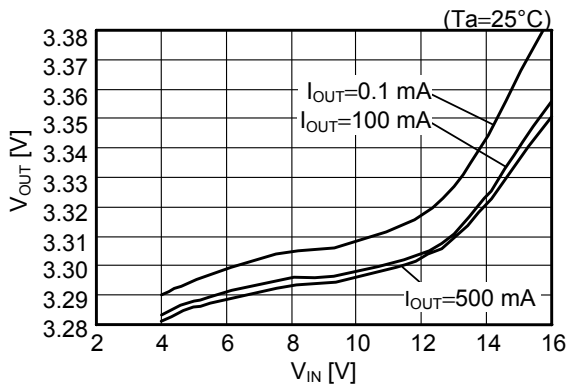

S-8521F50MC

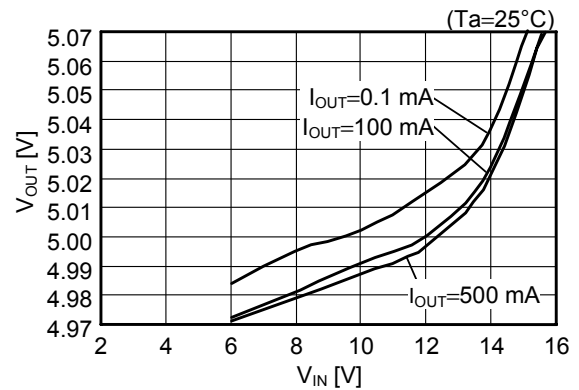

2. Transient Response Characteristics

2.1 Power-on (I_{OUT} : no load)

(1) S-8520 / 8521C30MC

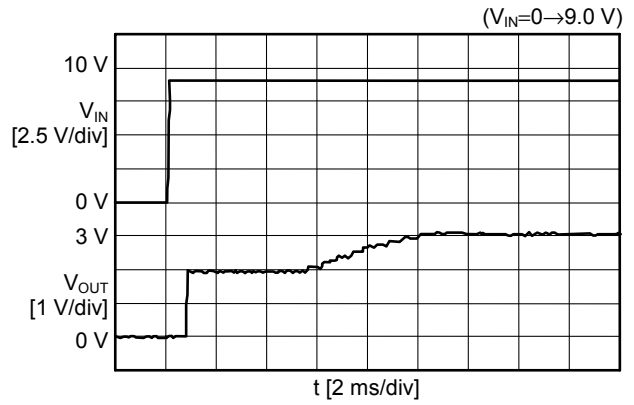
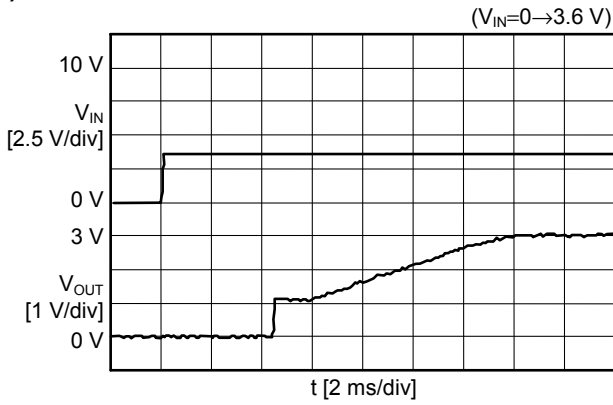

(2) S-8520 / 8521A30MC

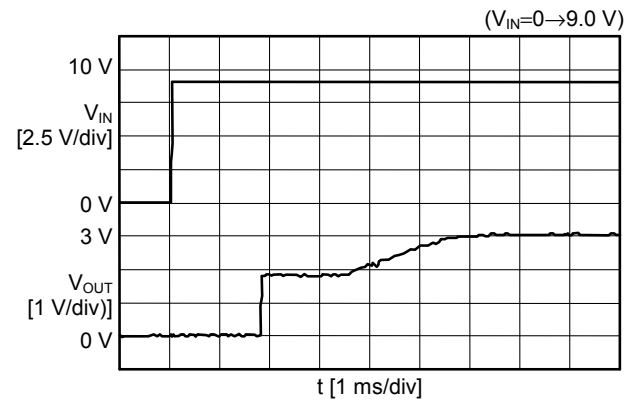
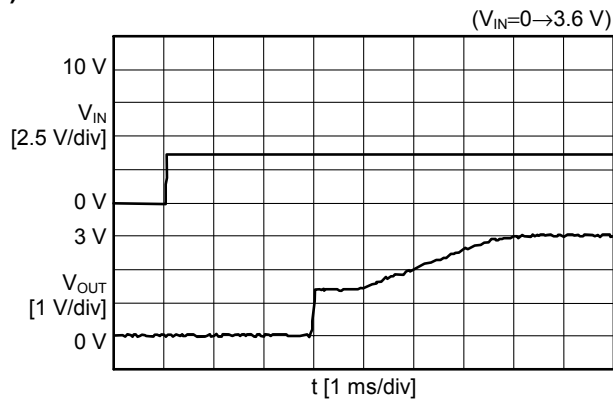

(3) S-8520 / 8521E33MC

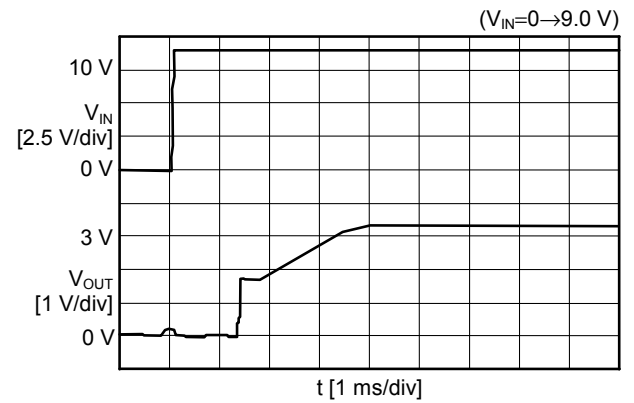
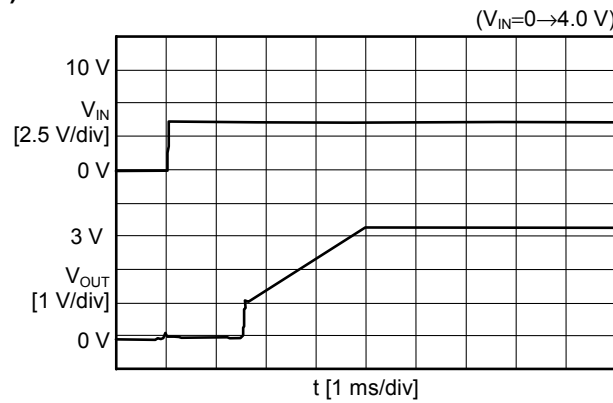

2.2 Shutdown pin response ($V_{ON/OFF} = 0 \rightarrow 1.8\text{ V}$, $I_{OUT} = \text{No load}$)

(1) S-8520 / 8521C30MC

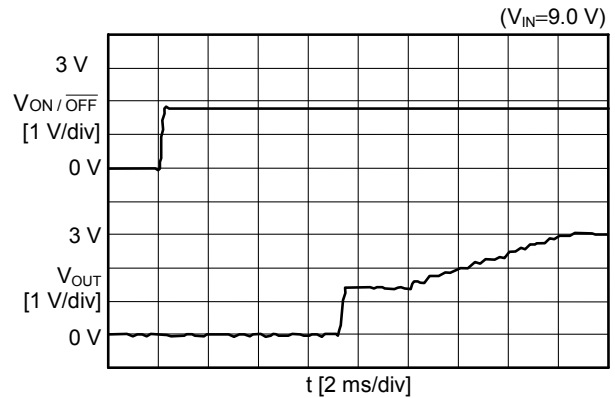
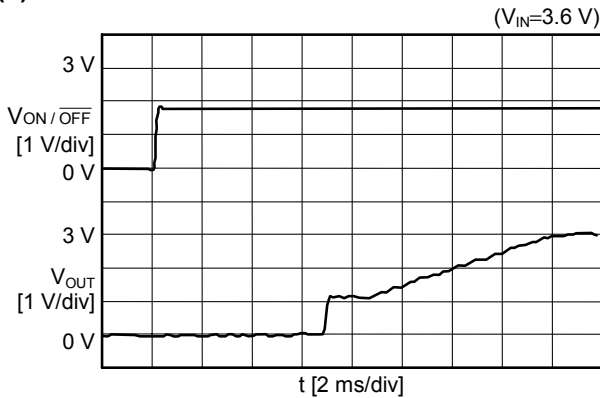

(2) S-8520 / 8521A30MC

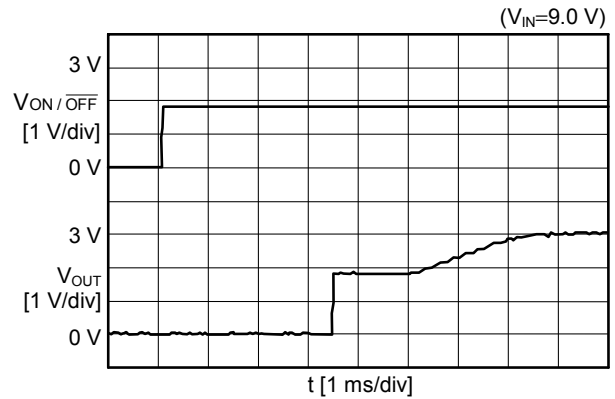
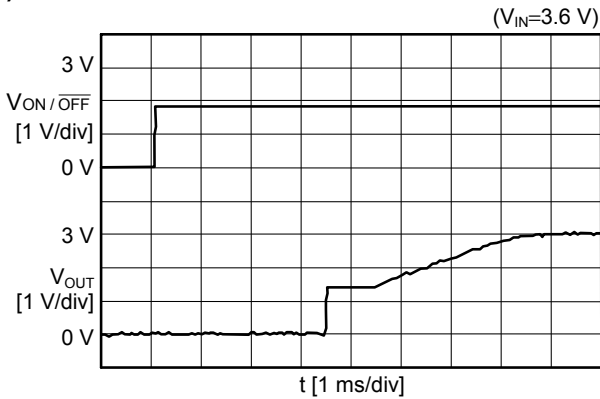

(3) S-8520 / 8521E33MC

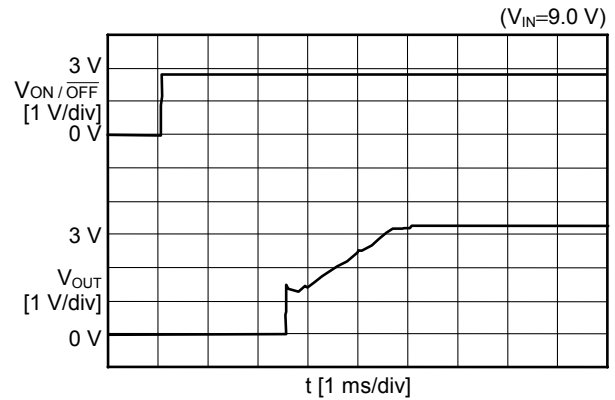
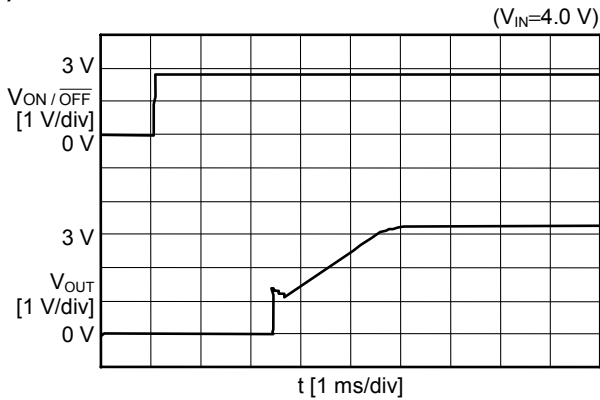

2.3 Supply voltage variation ($V_{IN}=4 \rightarrow 9 \text{ V}$, $9 \rightarrow 4 \text{ V}$)

(1) S-8520 / 8521C30MC

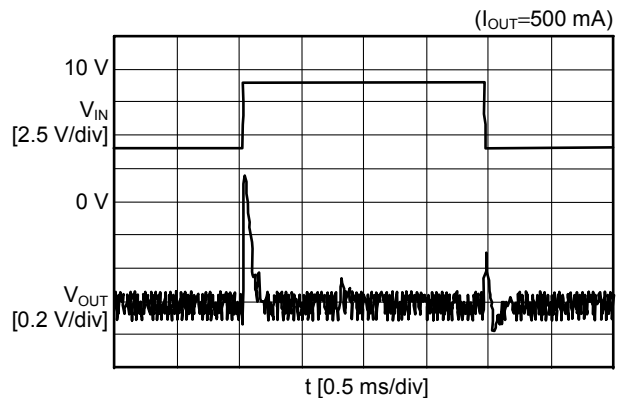
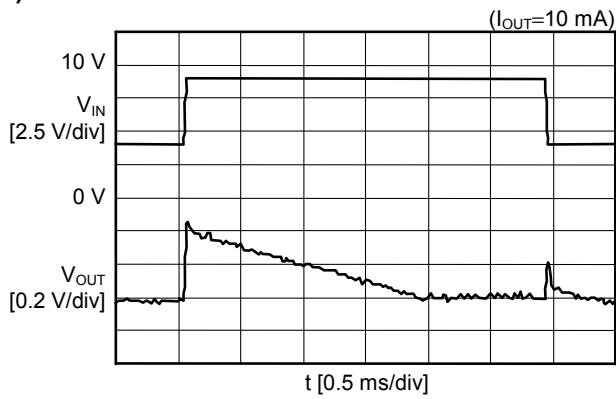

(2) S-8520 / 8521A30MC

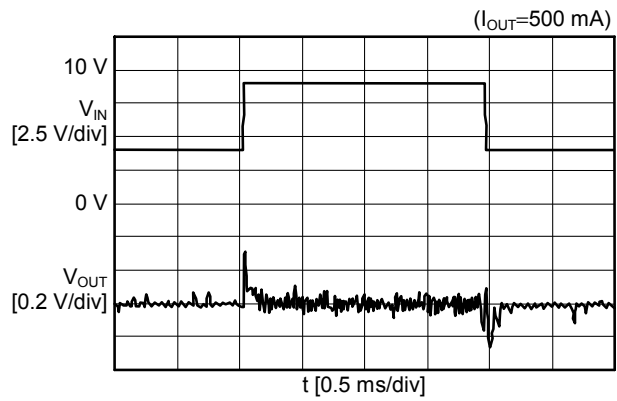
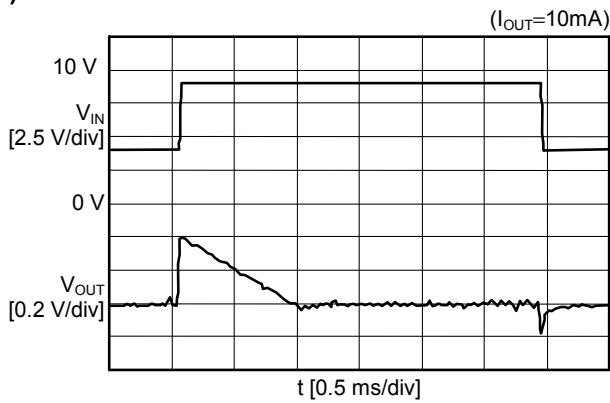

(3) S-8520 / 8521E33MC

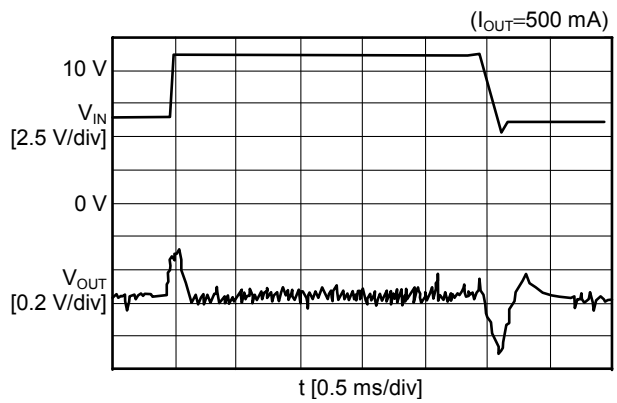
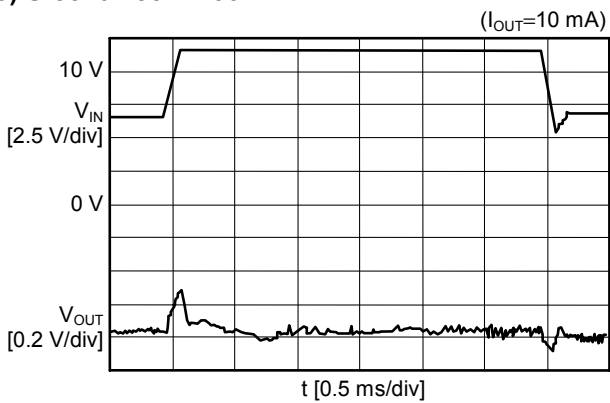

2.4 Load variation

(1) S-8520 / 8521C30MC

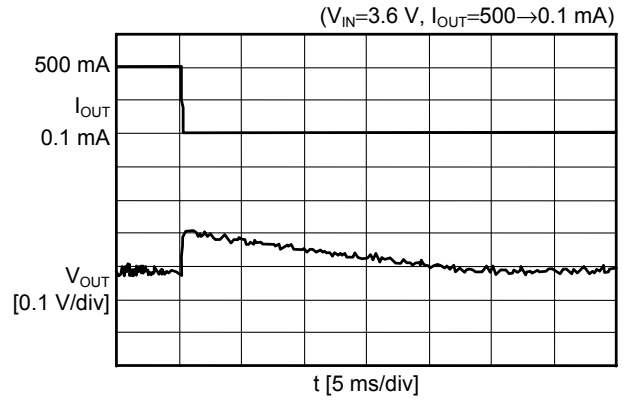
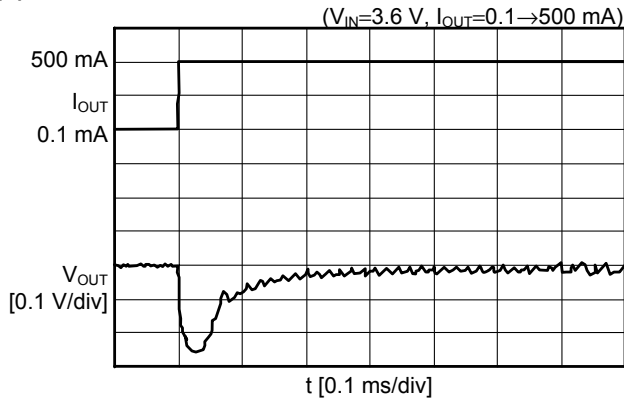

(2) S-8520 / 8521A30MC

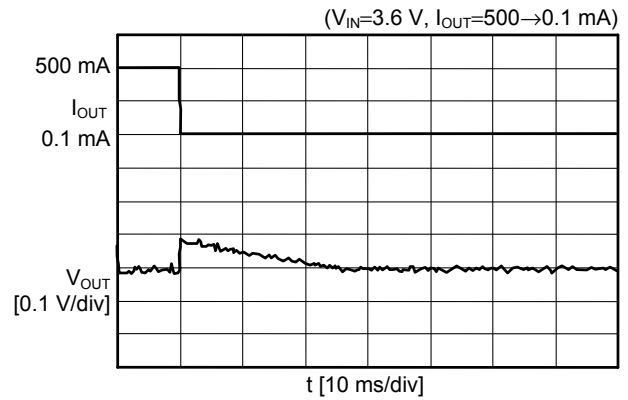
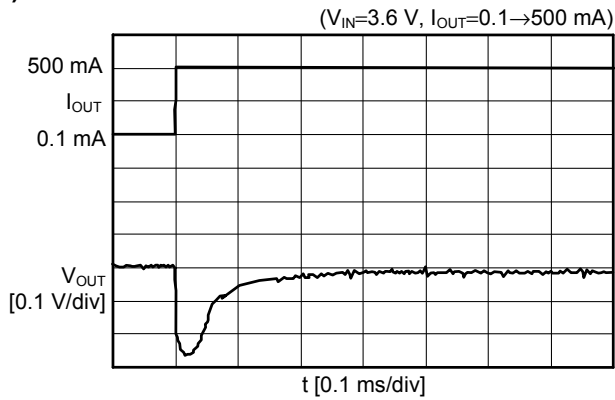

(3) S-8520 / 8521E33MC

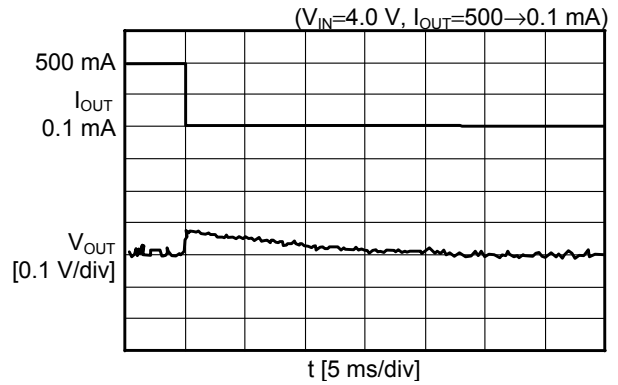
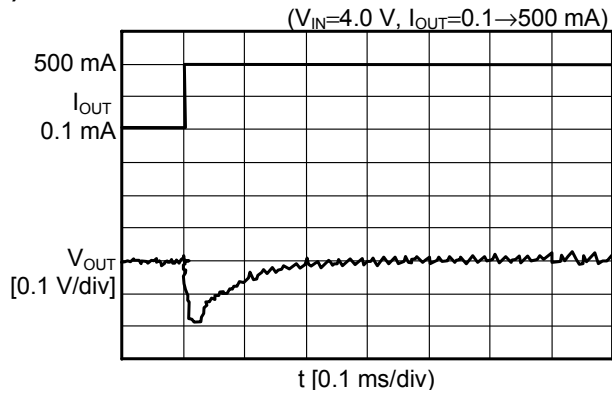

■ **Reference Data**

This reference data is intended to help you select peripheral components to be externally connected to the IC. Therefore, this information provides recommendations on external components selected with a view to accommodating a wide variety of IC applications. Characteristic data is duly indicated in the table below.

Table 11 External parts for efficiency data

Product name	Output voltage	Inductor	Transistor	Diode	Output capacitor	Application
S-8520B30MC	3.0 V	CD105 / 47 μ H	TM6201	MA737	47 μ F	$I_{OUT} \leq 1$ A, $V_{IN} \leq 10$ V
S-8520F33MC	3.3 V	D62F / 22 μ H		MA720	22 μ F	$I_{OUT} \leq 0.5$ A, $V_{IN} \leq 10$ V
S-8520F33MC		CDH113 / 22 μ H	IRF7606	MA737		$I_{OUT} \leq 1$ A, $V_{IN} \leq 16$ V
S-8521D30MC	3.0 V	CD54 / 47 μ F	TM6201	MA720	47 μ F \times 2	$I_{OUT} \leq 0.5$ A, $V_{IN} \leq 10$ V, With equipment standby mode
S-8521D30MC			IRF7606			$I_{OUT} \leq 0.5$ A, $V_{IN} \leq 16$ V, With equipment standby mode
S-8521B30MC		CD105 / 47 μ H	TM6201	MA737	47 μ F	$I_{OUT} \leq 1$ A, $V_{IN} \leq 10$ V, With equipment standby mode
S-8521B30MC			IRF7606			$I_{OUT} \leq 1$ A, $V_{IN} \leq 16$ V, With equipment standby mode
S-8521F33MC	3.3 V	D62F / 22 μ H	TM6201	MA720	22 μ F	$I_{OUT} \leq 0.5$ A, $V_{IN} \leq 10$ V, With equipment standby mode
S-8521F33MC		CDH113 / 22 μ H	IRF7606	MA737		$I_{OUT} \leq 1$ A, $V_{IN} \leq 16$ V, With equipment standby mode
S-8520B50MC	5.0 V	CD54 / 47 μ F	TM6201	MA720	47 μ F	$I_{OUT} \leq 0.5$ A, $V_{IN} \leq 10$ V
S-8520B50MC		CD105 / 47 μ H	IRF7606	MA737		$I_{OUT} \leq 1$ A, $V_{IN} \leq 16$ V
S-8520F50MC		D62F / 22 μ H	TM6201	MA720	22 μ F	$I_{OUT} \leq 0.5$ A, $V_{IN} \leq 10$ V
S-8520F50MC		CDH113 / 22 μ H	IRF7606	MA737		$I_{OUT} \leq 1$ A, $V_{IN} \leq 16$ V
S-8521D50MC		CD54 / 47 μ F	TM6201	MA720	47 μ F \times 2	$I_{OUT} \leq 0.5$ A, $V_{IN} \leq 10$ V, With equipment standby mode
S-8521D50MC		CD105 / 47 μ H	IRF7606	MA737		$I_{OUT} \leq 1$ A, $V_{IN} \leq 16$ V, With equipment standby mode
S-8521B50MC		CD54 / 47 μ F	TM6201	MA720	47 μ F	$I_{OUT} \leq 0.5$ A, $V_{IN} \leq 10$ V, With equipment standby mode
S-8521B50MC		CD105 / 47 μ H	IRF7606	MA737		$I_{OUT} \leq 1$ A, $V_{IN} \leq 16$ V, With equipment standby mode
S-8521F50MC		D62F / 22 μ H	TM6201	MA720	22 μ F	$I_{OUT} \leq 0.5$ A, $V_{IN} \leq 10$ V, With equipment standby mode
S-8521F50MC		CDH113 / 22 μ H	IRF7606	MA737		$I_{OUT} \leq 1$ A, $V_{IN} \leq 16$ V, With equipment standby mode

Table 12 External parts for Ripple data

Product name	Output voltage	Inductor	Transistor	R _b	C _b	Diode	Output capacitor
S-8520D30MC	3.0 V	CD105 / 47 μH	2SA1213Y	680 Ω	2200 pF	MA720	47 μF×2
S-8521D30MC							22 μF×2
S-8520B30MC							
S-8521B30MC							
S-8520F33MC	3.3 V	CDH113 / 22 μH	IRF7606	—	—	MA737	22 μF
S-8521F33MC				—	—		
S-8520D50MC	5.0 V	CD105 / 47 μH	2SA1213Y	680 Ω	2200 pF	MA720	47 μF×2
S-8521D50MC							22 μF×2
S-8520B50MC							
S-8521B50MC							
S-8520F50MC		CDH113 / 22 μH	IRF7606	—	—	MA737	22 μF
S-8521F50MC				—	—		

Table 13 Performance Data

Component	Product name	Manufacturer name	"L" value	DC resistance	Maximum allowable current	Diameter	Height
Inductor	CD54	Sumida Corporation	47 μH	0.37 Ω	0.72 A	5.8 mm	4.5 mm
	CD105			0.17 Ω	1.28 A	10.0 mm	5.4 mm
	CDH113		22 μH	0.09 Ω	1.44 A	11.0 mm	3.7 mm
	D62F	Toko Ink.		0.25 Ω	0.70 A	6.0 mm	2.7 mm
Diode	MA720	Matsushita Electric Industrial Co., Ltd.	Forward current 500 mA (at V _F =0.55 V)				
	MA737		Forward current 1.5 A (at V _F =0.5 V)				
Output capacity	F93	Nichicon Corporation	—				
	TE	Matsushita Electric Industrial Co., Ltd.	—				
External transistor (Bipolar PNP)	2SA1213Y	Toshiba Corporation	V _{CEO} 50 V max., I _C -2 A max., h _{FE} 120 to 240, SOT-89-3 package				
External transistor (MOS FET)	TM6201	Toyota Industries Corporation	V _{GS} 12 V max., I _D -2 A max., V _{th} -0.7 V min., C _{iss} 320 pF typ., R _{on} 0.25 Ω max. (V _{GS} =-4.5 V), SOT-89-3 package				
	IRF7606	International Rectifier Corporation	V _{GS} 20 V max., I _D -2.4 A max., V _{th} -1 V min., C _{iss} 470 pF typ., R _{on} 0.15 Ω max. (V _{GS} =-4.5 V), Micro 8 package				

1. Efficiency Characteristics: Output current (I_{OUT})-Efficiency (EFFI)

(1) S-8520B30MC

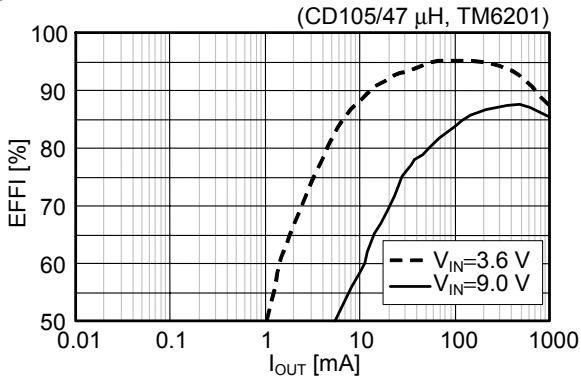

(2) S-8520F33MC

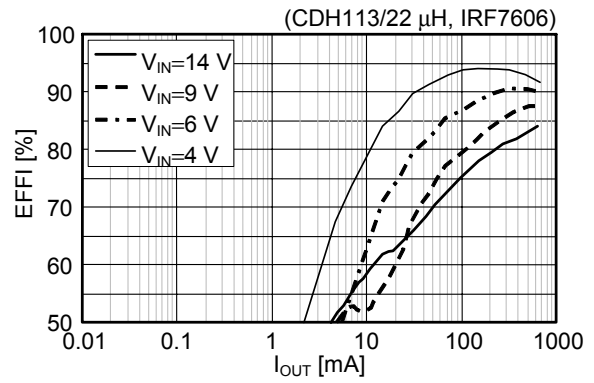
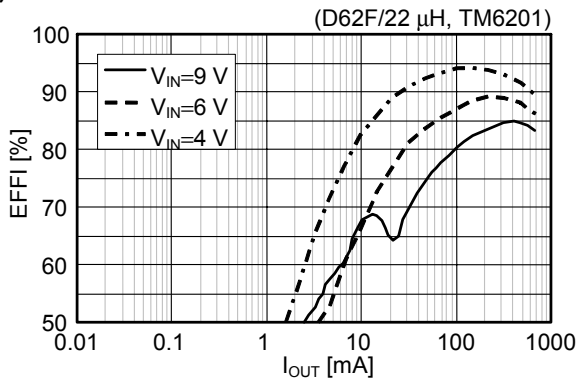

(3) S-8521D30MC

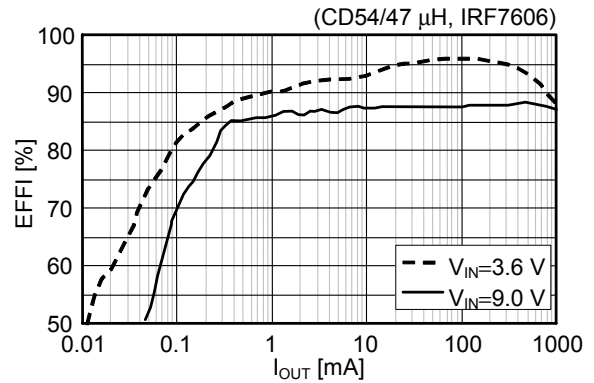
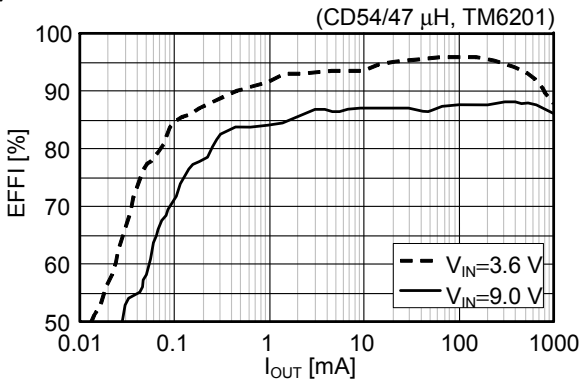

(4) S-8521B30MC

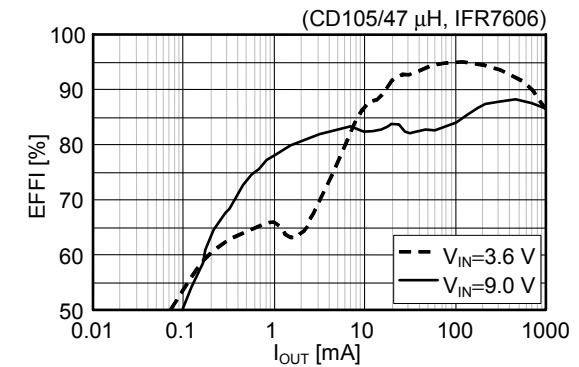
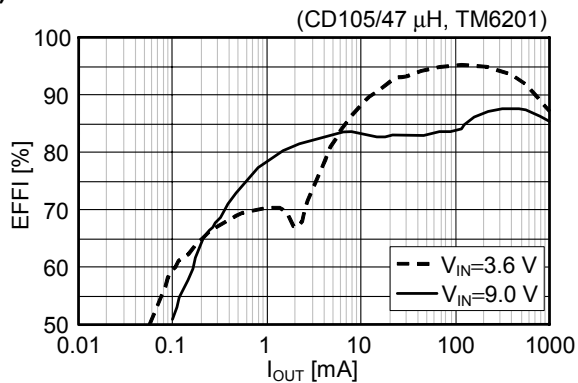

(5) S-8521F33MC

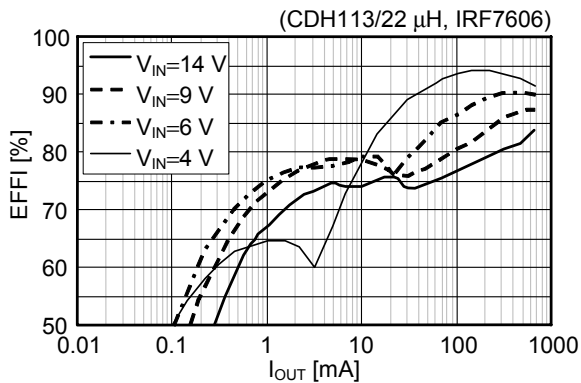
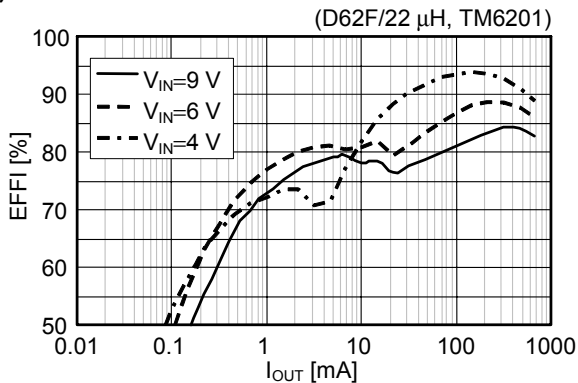

(6) S-8520B50MC

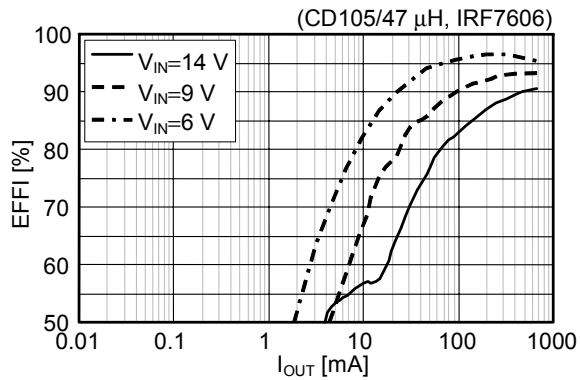
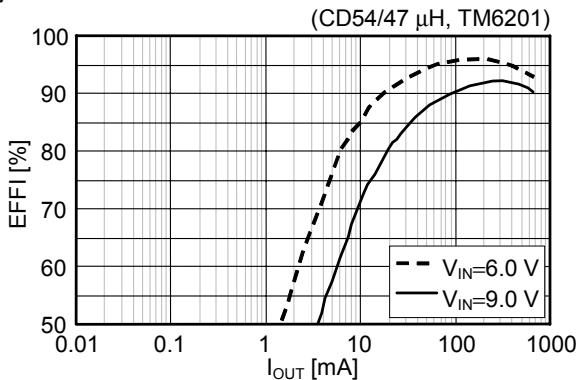

(7) S-8520F50MC

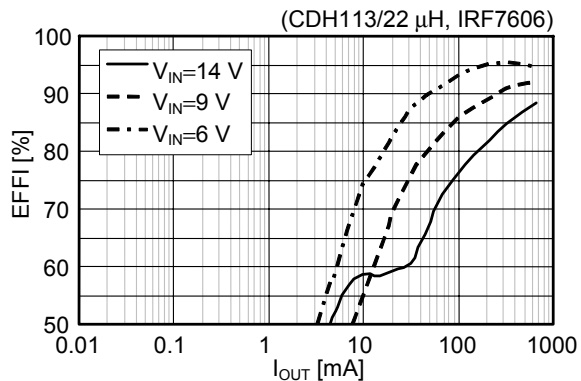
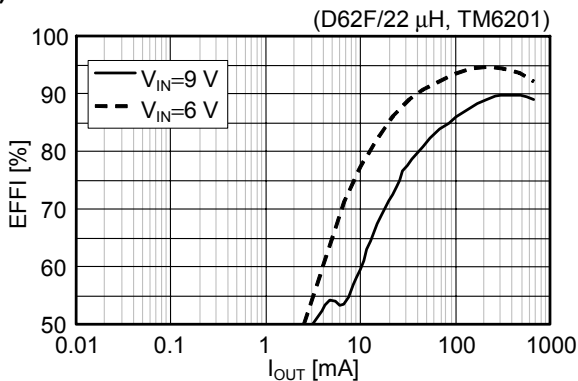

(8) S-8521D50MC

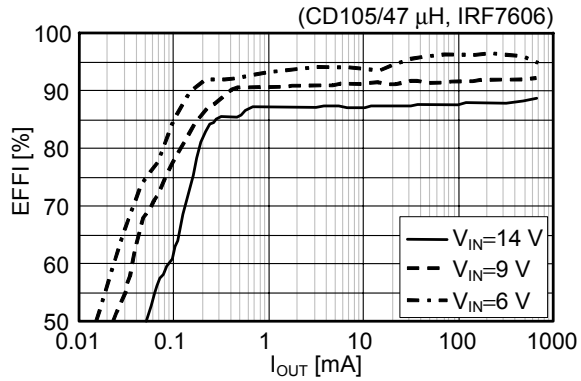
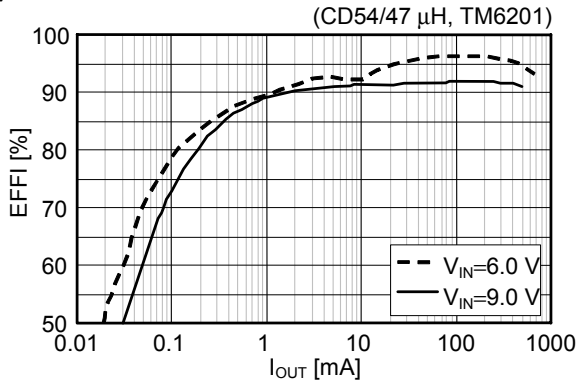

(9) S-8521B50MC

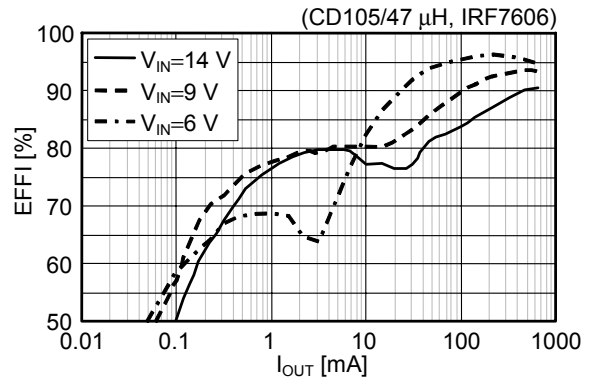
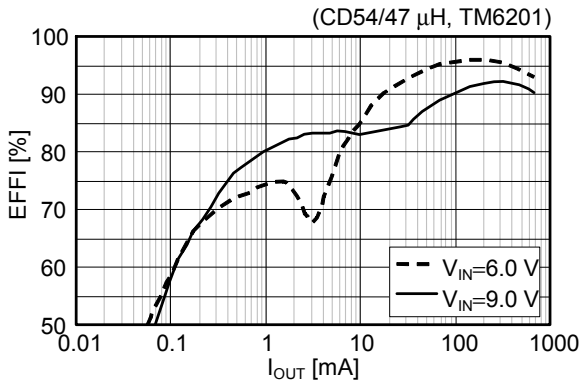

(10) S-8521F50MC

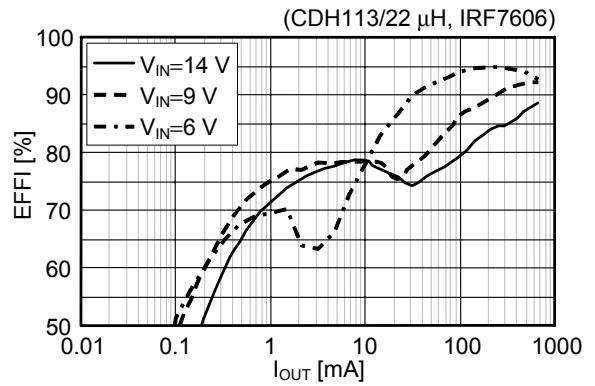
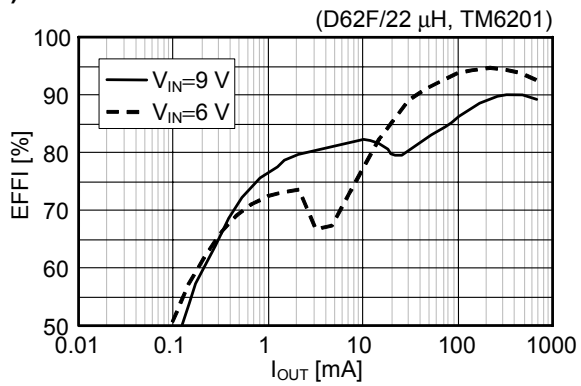

2. Ripple Voltage Characteristics: Ripple voltage (V_{rip})-Input voltage (V_{IN}) (L: CD105 / 47 μ F, Tr: 2SA1213, SBD: MA720)

(1) S-8520D30MC

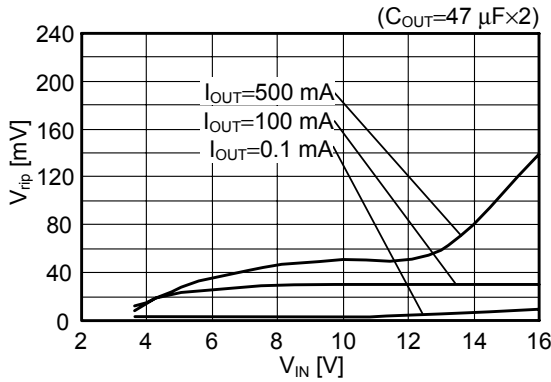

(2) S-8521D30MC

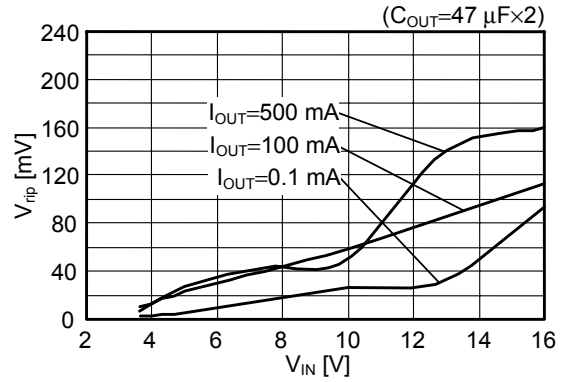

(3) S-8520B30MC

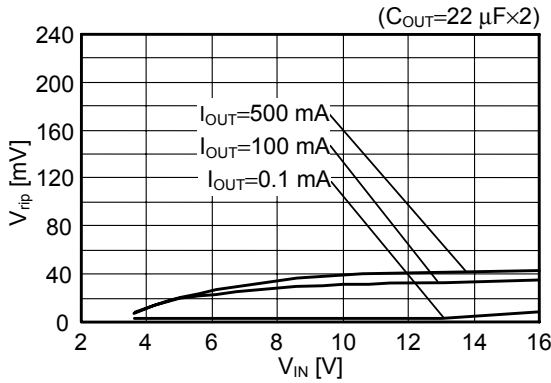

(4) S-8521B30MC

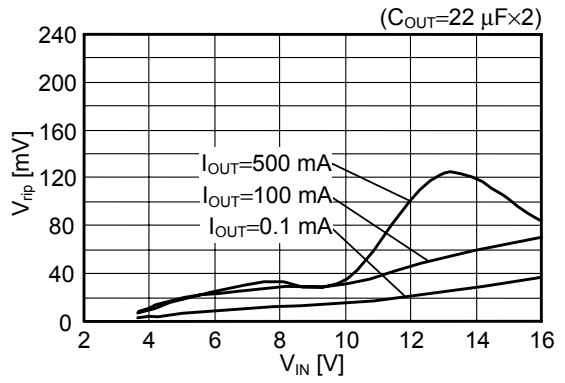

(5) S-8520F33MC

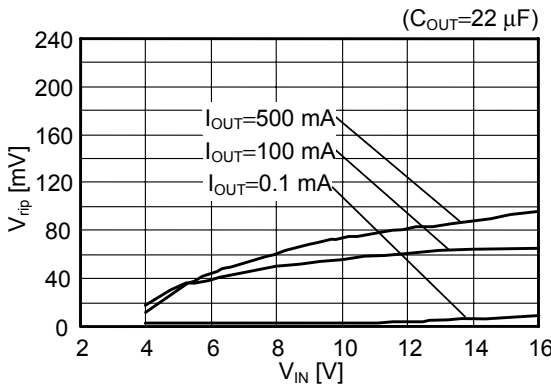

(6) S-8521F33MC

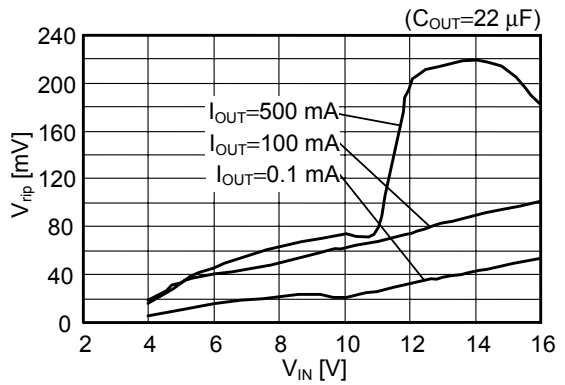

(7) S-8520D50MC

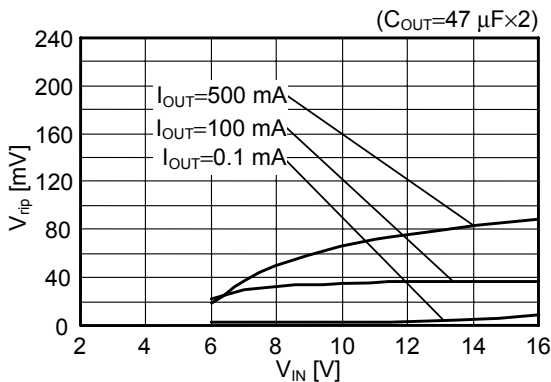

(8) S-8521D50MC

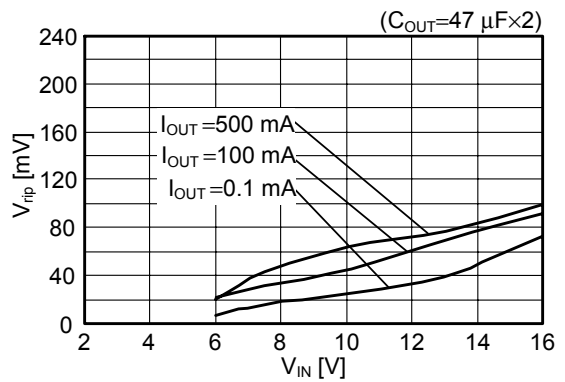

(9) S-8520B50MC

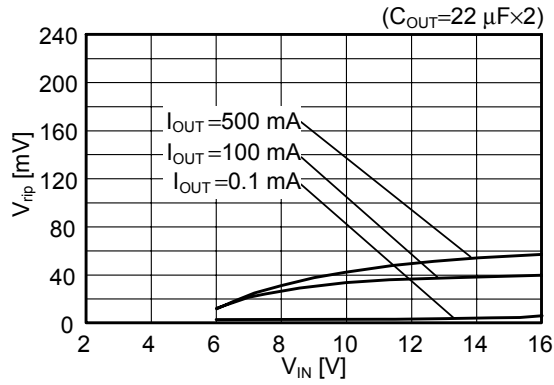

(10) S-8521B50MC

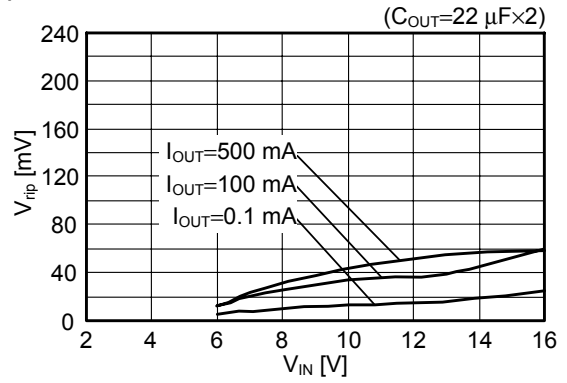

(11) S-8520F50MC

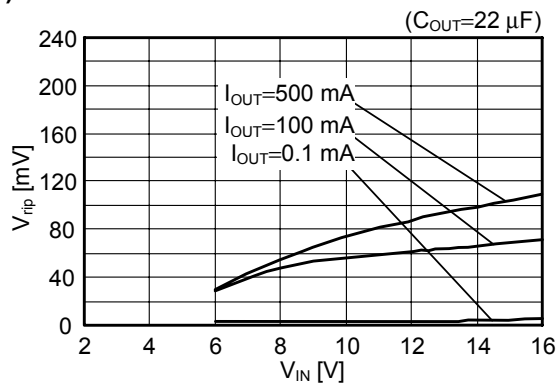

(12) S-8521F50MC

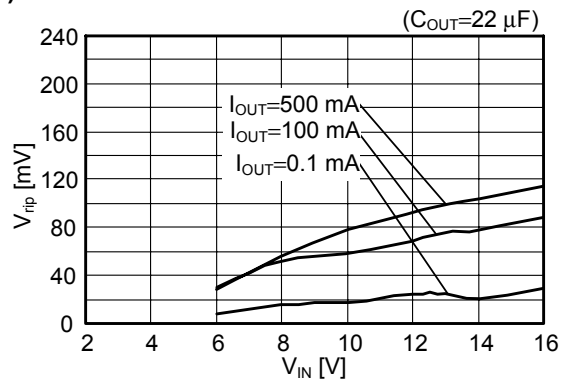

3. PWM / PFM switching characteristics: Input voltage (V_{IN})-Output current (I_{OUT})

(1) S-8521D30MC

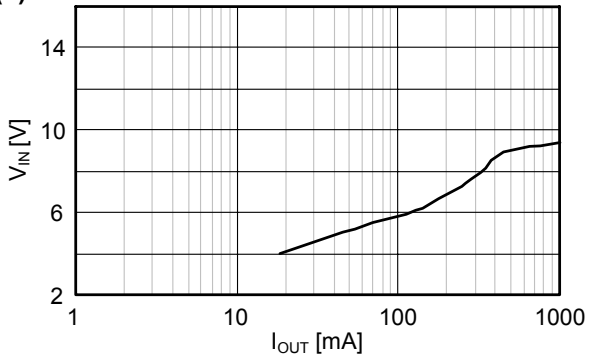

(2) S-8521B30MC

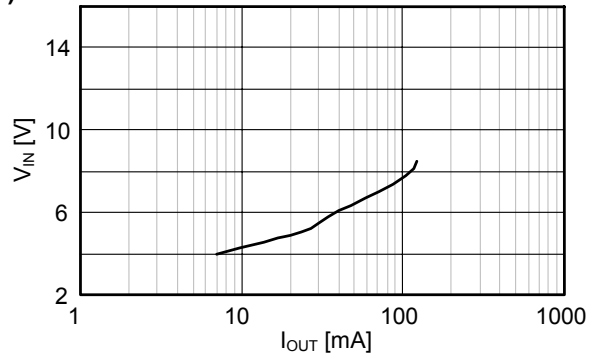

(3) S-8521F33MC

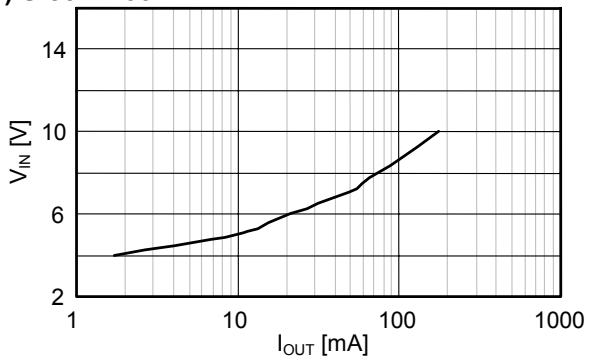

(4) S-8521D510MC

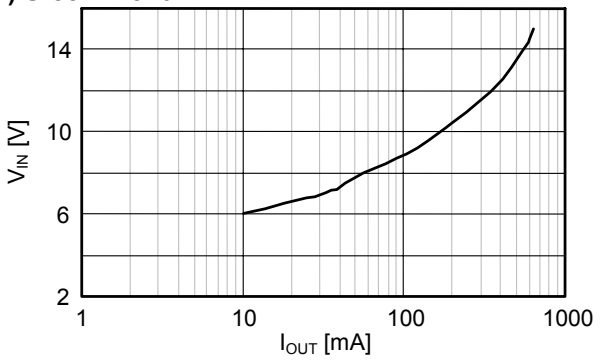

(5) S-8521B50MC

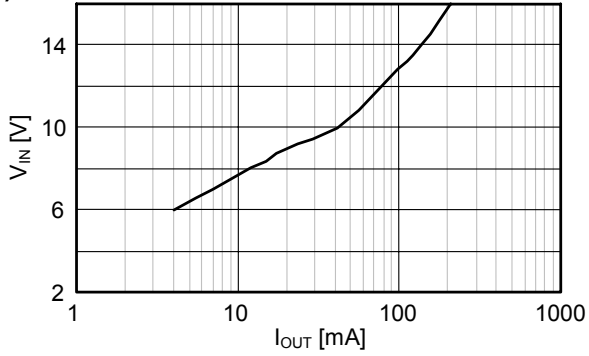

(6) S-8521F50MC

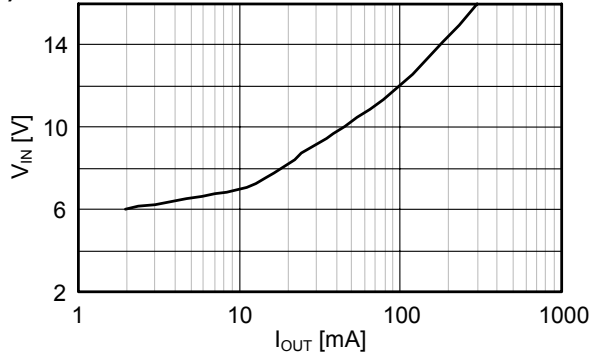

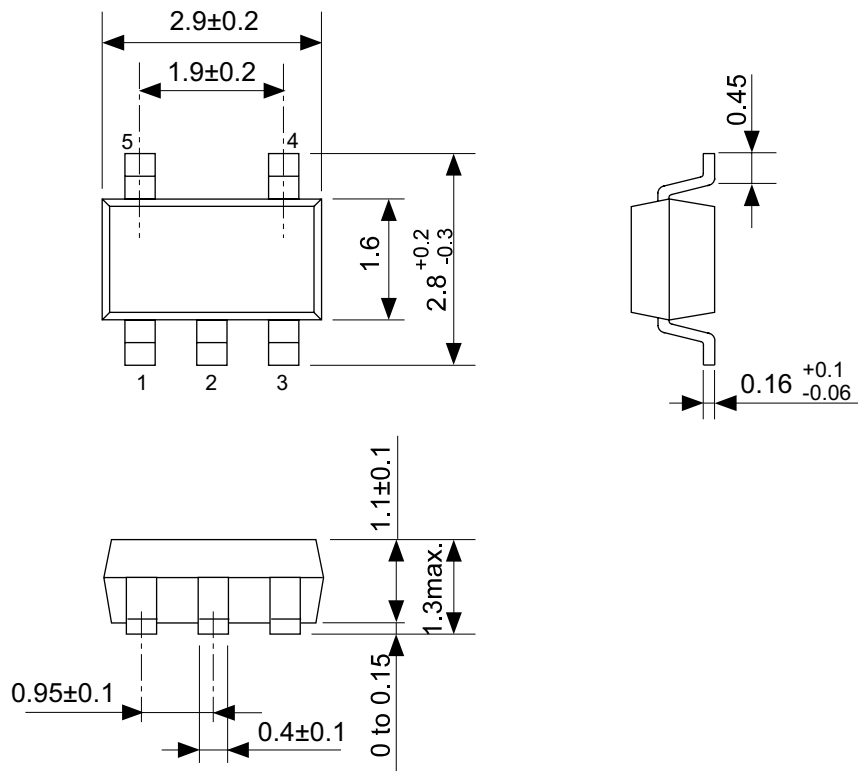

No. MP005-A-P-SD-1.2

TITLE	SOT235-A-PKG Dimensions
No.	MP005-A-P-SD-1.2
SCALE	
UNIT	mm
Seiko Instruments Inc.	

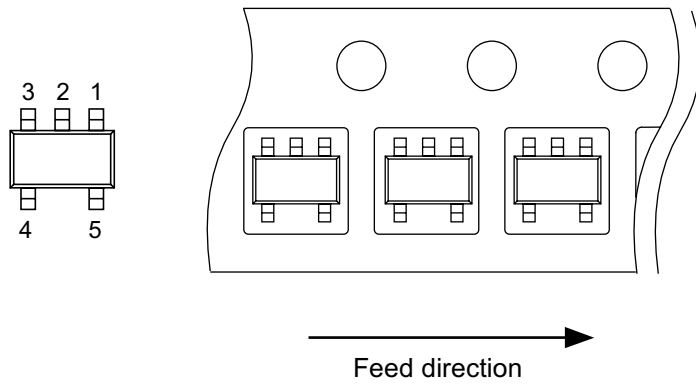
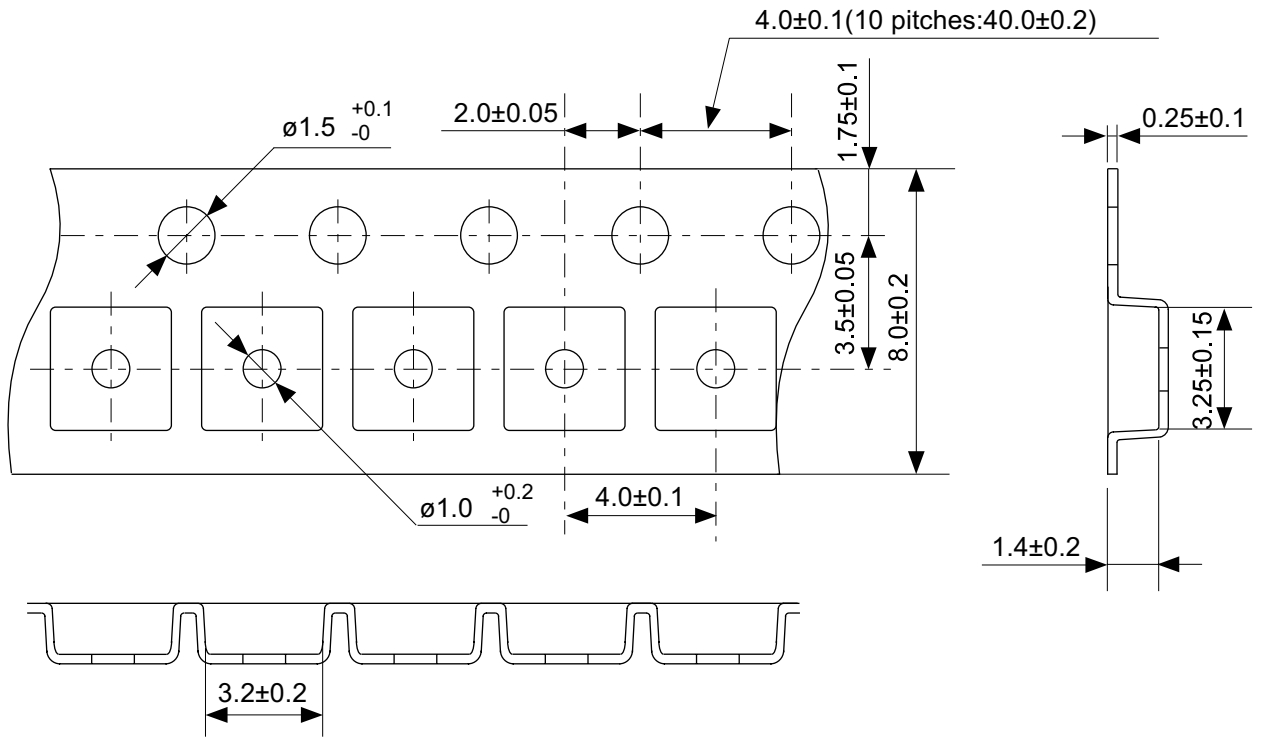

No. MP005-A-C-SD-2.1

TITLE	SOT235-A-Carrier Tape
No.	MP005-A-C-SD-2.1
SCALE	
UNIT	mm
Seiko Instruments Inc.	

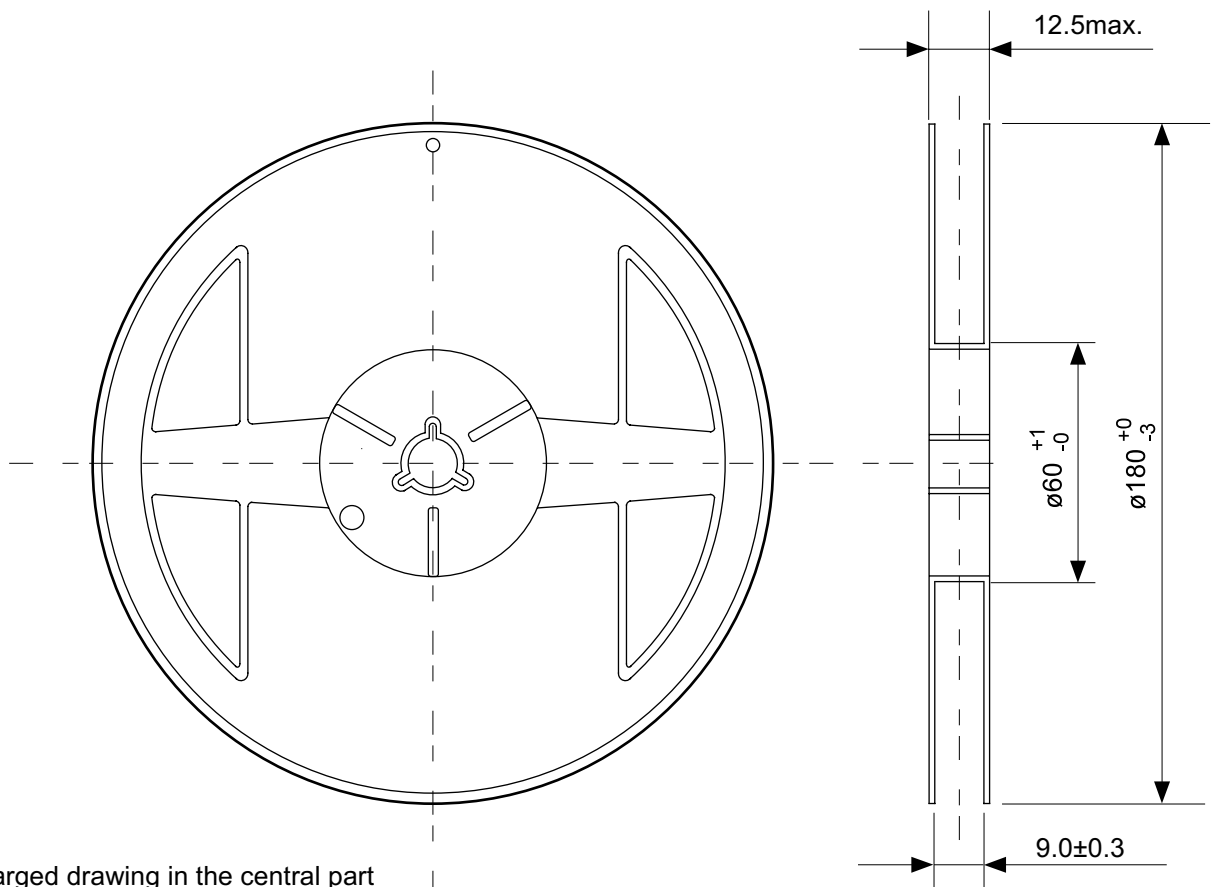

Enlarged drawing in the central part

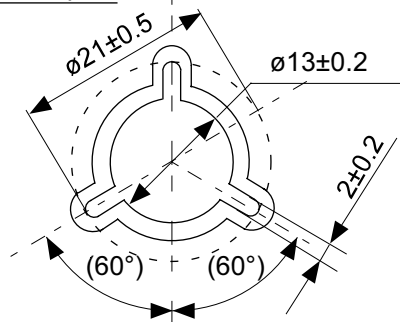

No. MP005-A-R-SD-1.1

TITLE	SOT235-A-Reel		
No.	MP005-A-R-SD-1.1		
SCALE		QTY.	3,000
UNIT	mm		
Seiko Instruments Inc.			

- The information described herein is subject to change without notice.
- Seiko Instruments Inc. is not responsible for any problems caused by circuits or diagrams described herein whose related industrial properties, patents, or other rights belong to third parties. The application circuit examples explain typical applications of the products, and do not guarantee the success of any specific mass-production design.
- When the products described herein are regulated products subject to the Wassenaar Arrangement or other agreements, they may not be exported without authorization from the appropriate governmental authority.
- Use of the information described herein for other purposes and/or reproduction or copying without the express permission of Seiko Instruments Inc. is strictly prohibited.
- The products described herein cannot be used as part of any device or equipment affecting the human body, such as exercise equipment, medical equipment, security systems, gas equipment, or any apparatus installed in airplanes and other vehicles, without prior written permission of Seiko Instruments Inc.
- Although Seiko Instruments Inc. exerts the greatest possible effort to ensure high quality and reliability, the failure or malfunction of semiconductor products may occur. The user of these products should therefore give thorough consideration to safety design, including redundancy, fire-prevention measures, and malfunction prevention, to prevent any accidents, fires, or community damage that may ensue.